

# Corning® Bioprocess Product Selection Guide



CORNING



## Bioprocess

Corning Life Sciences offers an extensive selection of vessels and closed system solutions for scaling-up both anchorage-dependent and suspension cells. Corning cell culture products are manufactured under strict process controls to deliver consistent product performance.

Customers can request a Certificate of Quality at [www.corning.com/lifesciences](http://www.corning.com/lifesciences) that details lot-specific information on component materials, sterility testing, and pyrogen testing. Also available are detailed product descriptions and drawings that highlight product dimensions and testing procedures.

### Product Ordering Information

For information on Purchasing Options, Terms and Conditions of Sale, Return and Repair Policies, and Warranty/Guarantee Registration, visit our website at [www.corning.com/how-to-buy](http://www.corning.com/how-to-buy).

*Products may not be available in all markets.*

Roller Bottles .....	1
Corning® CellSTACK® Culture Chambers .....	2
Corning HYPERStack® Cell Culture Vessels .....	5
Corning CellCube® Systems .....	6
Closed System Solutions .....	7
Corning Ascent® Fixed Bed Reactor .....	8
Microcarriers .....	10
Erlenmeyer Shaker Flasks .....	12
Mini Bioreactor .....	14
Disposable Spinner Flasks .....	14
Preassembled Closed System Solutions for Corning Centrifuge Tubes .....	16
Preassembled Closed System Solutions for Corning Polystyrene Storage Bottles .....	17
Single-use Bioproduction Bags .....	18
Custom Fabrication and Assembly Services .....	19
Multi-purpose Bioproduction Bags .....	20
Cryopreservation Bags .....	21
Tubing Sets .....	22
Single-use Bags for Corning HYPERStack Vessels .....	23
<b>Index .....</b>	<b>26</b>

# Roller Bottles



## Roller Bottle Application Tips

- ▶ Corning recommends 0.2 mL to 0.3 mL of medium per cm<sup>2</sup> of growth area.
- ▶ Corning recommends setting roller rack speeds to provide 0.5 to 1.0 rpm.



Easy grip vent cap



Ideal for a variety of rolling applications, Corning Roller Bottles are made of USP Class VI Polystyrene. They are single-use, sterile, feature laser-etched or in-mold graduations and are available in 490 cm<sup>2</sup>, 850 cm<sup>2</sup>, 1,700 cm<sup>2</sup> pleated, and 1,750 cm<sup>2</sup> sizes. Caps are available in solid High Density Polyethylene (HDPE) or vented HDPE with a 0.2 mm microporous PTFE membrane.

- ▶ Treated for optimal cell attachment
- ▶ One piece seamless construction
- ▶ All bottles have printed lot numbers to aid in product traceability
- ▶ Sterility Assurance Level (SAL) of 10<sup>-6</sup>
- ▶ Nonpyrogenic

## Expected Cell Yields and Recommended Medium Volumes

Description	Approximate Growth Area (cm <sup>2</sup> )	Average Cell Yield*	Recommended Medium Volume (mL)
490 cm <sup>2</sup> roller bottle	490	4.9 x 10 <sup>7</sup>	100 - 150
850 cm <sup>2</sup> roller bottle	850	8.5 x 10 <sup>7</sup>	170 - 255
1,700 cm <sup>2</sup> roller bottle	1,700	1.7 x 10 <sup>8</sup>	340 - 510
1,750 cm <sup>2</sup> roller bottle	1,750	1.75 x 10 <sup>8</sup>	350 - 525

\*Assumes an average yield of 1 x 10<sup>5</sup> cells/cm<sup>2</sup> from a 100% confluent culture. Yields from many cell types can be lower than this.

## Roller Bottles, Standard Surface

Cat. No.	Surface	Surface Area (cm <sup>2</sup> )	Cap Style	Graduations	Qty/Pk	Qty/Cs
430195	TC-treated	490	Plug seal	No	2	40
430849	TC-treated	850	Easy grip	Yes	2	40
431133	TC-treated	850	Easy grip	Yes	20	20
431198	TC-treated	850	Easy grip vent	Yes	2	40
430851	TC-treated	850	Easy grip	Yes	5	40
431321	TC-treated	850	Easy grip	Yes	22	44
31292*	TC-treated	850	Easy grip vent	Yes	20	40
3907	Corning CellBIND®	850	Easy grip	Yes	2	40
431329	Corning CellBIND	850	Easy grip vent	Yes	2	40
431345*	Corning CellBIND	850	Easy grip	Yes	20	20
431344	Corning CellBIND	850	Easy grip	Yes	22	44
431644	Untreated	850	Easy grip	Yes	1	40
430699	TC-treated	1,750	Easy grip	Yes	10	20

\*Made to order. Please contact your local Corning Account Representative for more information.

## Roller Bottles, Expanded Surface

Ribbed design provides twice the surface area with the same exterior dimensions

Cat. No.	Surface	Surface Area (cm <sup>2</sup> )	Cap Style	Graduations	Qty/Pk	Qty/Cs
430852	TC-treated	1,700	Easy grip	Yes	2	40
430853	TC-treated	1,700	Easy grip	Yes	5	40
431135	TC-treated	1,700	Easy grip	Yes	20	20
431191	TC-treated	1,700	Easy grip vent	Yes	20	20
431134	Corning CellBIND	1,700	Easy grip	Yes	20	20

## Roller Bottle Caps, Polyethylene

Caps are available separately and are individually wrapped. Easy grip vent cap is designed for applications requiring consistent gas exchange.

Cat. No.	Cap Style	Qty/Pk	Qty/Cs
431132	Easy grip vent cap	1	300

## Aseptic Transfer Caps for Corning Roller Bottles

Cat. No.	Description	Tubing	Tubing Length with Connector	Tubing Connection	Qty/Pk	Qty/Cs
10043	Disposable aseptic transfer cap for roller bottle with 0.2 μm filter	Chemically resistant, heat sealable flexible tubing, 3/8" ID, 1/2" OD	8"	Male MPC	1	2

MPC = medical plastic coupler.

# Corning® CellSTACK® Culture Chambers



- ▶ Available in five sizes:
  - 1-Layer with 636 cm<sup>2</sup> cell growth area
  - 2-Layer with 1,272 cm<sup>2</sup> cell growth area
  - 5-Layer with 3,180 cm<sup>2</sup> cell growth area
  - 10-Layer with 6,360 cm<sup>2</sup> cell growth area
  - 40-Layer with 25,440 cm<sup>2</sup> cell growth area
- ▶ Choice of traditional tissue culture (TC) treatment, Corning CellBIND® surface for enhanced cell attachment, or Ultra-Low Attachment (ULA) surface for reduced cell attachment on select CellSTACK chambers.
  - Corning CellBIND surface
    - Great for reducing serum levels
    - Better attachment increases cell yields
  - Ultra-Low Attachment surface
    - Maintains cells in an unattached state
    - Prevents stem cells from attachment-mediated differentiation
    - Reduces binding of attachment and serum proteins to the substrate
- ▶ Greater chamber durability
  - Superior mechanical strength and structural integrity
  - Standard 33 mm vented caps offer larger openings with threaded closures
  - 100% leak-tested prior to shipping
- ▶ Nonpyrogenic
- ▶ Sterility Assurance Level (SAL) of 10<sup>-6</sup>
- ▶ Manufactured under cGMP conditions

## Corning CellSTACK Culture Chambers

Cat. No.	Description	Surface	Growth Area (cm <sup>2</sup> )	Qty/Pk	Qty/Cs
3303	CellSTACK 1-chamber	Ultra-Low Attachment	636	1	8
3330	CellSTACK 1-chamber	Corning CellBIND	636	1	8
3268	CellSTACK 1-chamber	TC-treated	636	1	8
3310	CellSTACK 2-chamber	Corning CellBIND	1,272	1	5
3269	CellSTACK 2-chamber	TC-treated	1,272	1	5
3311	CellSTACK 5-chamber	Corning CellBIND	3,180	1	2
3319	CellSTACK 5-chamber	TC-treated	3,180	1	2
3313	CellSTACK 5-chamber	TC-treated	3,180	1	8
3320	CellSTACK 10-chamber	Corning CellBIND	6,360	1	6
3312	CellSTACK 10-chamber	Corning CellBIND	6,360	1	2
3270	CellSTACK 10-chamber	TC-treated	6,360	1	2
3271	CellSTACK 10-chamber	TC-treated	6,360	1	6
3321	CellSTACK 40-chamber	Corning CellBIND	25,440	1	2
3272	CellSTACK 40-chamber	TC-treated	25,440	1	2

## Corning® CellSTACK® Accessories

Corning offers a variety of accessories to simplify handling and reduce contamination risks when processing Corning CellSTACK chambers.



Corning CellSTACK stacking device

### Better Filling

Optional filling caps allow direct aseptic transfer of media and cells via pumping or gravity feed. Coupling devices are available with or without integrally sealed, chemically resistant, heat-sealable flexible tubing. Optional filling caps with attached hydrophobic membrane filters provide for gas exchange and faster aseptic venting during liquid transfers. Additional sterile vented or unvented 33 mm replacement caps are also available (see table below).

### Better Options

For additional filling and fluid management options for our CellSTACK vessels, consider Corning's suite of closed system solutions. These solutions provide sterile, easy-to-use options that are available as stand-alone manifolds or accessories, or pre-integrated on the CellSTACK vessel. Contact your Corning Bioprocess Specialist for available closed system products or to configure one specifically for your process (see Closed System Solutions for Corning CellSTACK vessels section).

### Corning CellSTACK Accessories

Cat. No.	Description	Qty/Pk	Qty/Cs
3331	Corning CellSTACK stacking device, ABS, nonsterile	1	5
3732	Universal cap, polyethylene, 33 mm, with vented overcap, double-bagged, sterile	1	4
3969	Solid cap, polyethylene, 33 mm, sterile	1	6
3968	Vent cap, polyethylene, 33 mm, 0.2 µm membrane, sterile	1	6



Universal cap, vented overcap

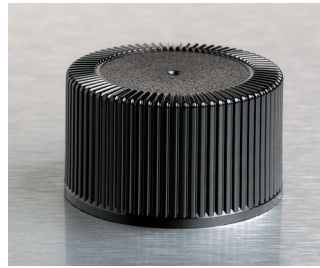

Solid cap, not vented



Vented cap

### Aseptic Transfer Caps for Corning CellSTACK Culture Chambers

Cat. No.	Description	Tubing/Cap Inside Diam.	Tubing Length	Tubing Connection	Qty/Pk	Qty/Cs
3282	Fill cap with tubing, FLL	1/8"	18"	FLL	1	5
3333	Fill cap with Male MPC	1/4"	28"	Male MPC	1	4
3328	Fill cap with Female MPC	1/4"	N/A	Female MPC	1	4
3334	Fill cap with Male MPC	1/4"	N/A	Male MPC	1	4
3283	Fill cap with tubing and barbed fittings	3/8"	18"	Barbed fitting	1	5
3339	Fill cap with Male MPC	3/8"	N/A	Male MPC	1	4
3329	Fill cap with Female MPC coupling	3/8"	N/A	Female MPC	1	4
11902	Fill cap with tubing and Female MPC	3/8"	28"	Female MPC	1	4
3284	Vent cap with tubing and 37 mm hydrophobic glass laminate 1.0 µm vent filter	1/4"	2 3/4"	N/A	1	4
3281	Vent cap with tubing and 50 mm hydrophobic PVDF 0.2 µm vent filter	3/8"	2 3/4"	N/A	1	5



Vent cap with tubing (Cat. No. 3281)

### Aseptic Transfer Caps for Corning® CellSTACK® Culture Chambers (continued)



Fill cap, male MPC, 3/8" (9.5 mm) ID (Cat. No. 3339)

Cat. No.	Description	Tubing/Cap Inside Diam.	Tubing Length	Tubing Connection	Qty/ Pk	Qty/ Cs
3324	Two (2) vented over caps and one (1) solid over cap	N/A	N/A	N/A	5	100
11757	Barbed cap with Female MPC	3/8" ID	6"	Female MPC	1	5
11759	Barbed cap with AseptiQuik® G series	3/8" ID	24"	AseptiQuik® G series	1	5
11758	Barbed cap with Female MPC	3/8" ID	24"	Female MPC	1	5
3718	CellSTACK screw cap vent accessory with tubing and 50 mm hydrophobic PVDF 0.2 µm vent filter	3/8"	3"	N/A	1	5
3719	CellSTACK screw cap fill accessory with tubing	3/8"	15"	FLL	1	5
11931	CellSTACK manifold - 4 Luer and 2 MPC connections	N/A	N/A	N/A	1	4

FLL = female Luer lock, MPC = medical plastic coupler, MLL = male Luer lock.

### Preassembled Closed System Solutions for Corning CellSTACK® Culture Chambers

Cat. No.	Description	Tubing	Tubing Length	Qty/ Pk	Qty/ Cs
11760*	CellSTACK 2-layer, Female MPC	Chemically resistant, heat sealable flexible tubing, 3/8" ID, 5/8" OD	6"	1	8
11761*	CellSTACK 5-layer, Female MPC	Chemically resistant, heat sealable flexible tubing, 3/8" ID, 5/8" OD	6"	1	4
11762*	CellSTACK 10-layer, Female MPC	Chemically resistant, heat sealable flexible tubing, 3/8" ID, 5/8" OD	6"	1	4
11763*	CellSTACK 2-layer, AseptiQuik® G series	Chemically resistant, heat sealable flexible tubing, 3/8" ID, 5/8" OD	24"	1	8
11764*	CellSTACK 5-layer, AseptiQuik® G series	Chemically resistant, heat sealable flexible tubing, 3/8" ID, 5/8" OD	24"	1	4
11765*	CellSTACK 10-layer, AseptiQuik® G series	Chemically resistant, heat sealable flexible tubing, 3/8" ID, 5/8" OD	24"	1	4
11766*	CellSTACK 2-layer, Female MPC	Chemically resistant, heat sealable flexible tubing, 3/8" ID, 5/8" OD	24"	1	8

\*Made to order. Please contact your local Corning Account Representative for more information.

# Corning® HYPERStack® Cell Culture Vessels



## 2 Sizes Available

(cm<sup>2</sup> = surface area)

12-layer = 6,000 cm<sup>2</sup>

36-layer = 18,000 cm<sup>2</sup>

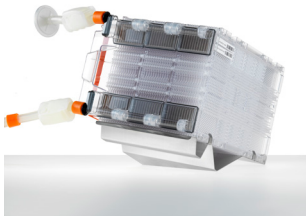

Corning HYPERStack Nest accessory (Cat. No. 10047)

## Closed System for High Yield Cell Growth

Corning's High Yield **PER**formance (HYPER) platform – the Corning HYPERStack cell culture vessel – combines the best of two Corning products: the Corning CellSTACK culture chamber and the Corning HYPERFlask® vessel. The utilization of the proprietary gas-permeable film technology provided in the format of the CellSTACK culture chamber allows the HYPERStack vessel to be the most efficient, scalable cell culture vessel for adherent cell culture available today.

- ▶ **More cells** – provides up to 5X the growth surface area of a traditional cell culture vessel of comparable footprint
- ▶ **Closed system** – no open fluid manipulations
- ▶ **Scalable product** – multiple size offerings support scale-up and scale-out
- ▶ **Ergonomic design** – easier manipulation with handling equipment and accessories
- ▶ **Fixed media volume** – 0.2 mL/cm<sup>2</sup> fills vessel for less volumetric waste

View HYPERStack protocol videos and application notes at [www.corning.com/hyperstack](http://www.corning.com/hyperstack).

## Corning® HYPERStack Vessels

Cat. No.	Description	Growth Area (cm <sup>2</sup> )	Qty/ Pk	Qty/ Cs
20012	Corning HYPERStack 12-layer cell culture vessel, Corning CellBIND® surface	6,000	1	4
20013	Corning HYPERStack 12-layer cell culture vessel, non-treated surface	6,000	1	4
20037	Corning HYPERStack 36-layer cell culture vessel, non-treated surface	18,000	1	2
20036	Corning HYPERStack 36-layer cell culture vessel, Corning CellBIND surface	18,000	1	2

## Corning HYPERStack Accessories

Cat. No.	Description	Qty/ Pk	Qty/ Cs
10042	Disposable tubing set for use with glass bottle, 3/8" ID x 1/2" OD, animal component-free, chemically resistant, heat sealable flexible tubing, 18" in length, sterile	1	2
10043	Disposable tubing set for use with 850 cm <sup>2</sup> polystyrene roller bottle, 3/8" ID x 1/2" OD, animal component-free, chemically resistant, heat sealable flexible tubing, 0.2 µm filter, MPC quick connect	1	2
431644	850 cm <sup>2</sup> bottle, Easy Grip cap, not treated, polystyrene, sterile	1	40
431518	2L Erlenmeyer flask with dip tube with 0.2 µm vent, male MPC, resistant, heat sealable flexible tubing, 1/4" ID, 3/8" OD	1	3
11501	5L Erlenmeyer flask with dip tube with 0.2 µm filter, male MPC chemically resistant, heat sealable flexible tubing, 1/4" ID, 3/8" OD	1	2
11370	Manifold accessory with 5 connections for Corning HYPERStack vessels, standard tubing lengths	1	2
11380	Manifold accessory with 5 connections for Corning HYPERStack vessels, extended tubing lengths	1	2
10047*	Corning HYPERStack Nest accessory	1	1

\*Made to order. Please contact your local Corning Account Representative for more information.  
MPC = medical plastic coupler.

# Corning® CellCube® Systems

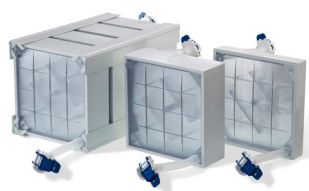

Corning CellCube 10-, 25-, and 100-layer modules with AseptiQuik® connectors

The Corning CellCube system is a modular, scalable platform for adherent cell culture. It is well suited to diverse applications ranging from cell and gene therapy to viral vector and vaccine production. At the core of the system is the Corning CellCube module, consisting of 10, 25, or 100 parallel, polystyrene plates with thin, sealed laminar flow spaces between adjacent plates providing cell growth surface area ranging from 8,500 to 85,000 cm<sup>2</sup> in a compact footprint.

The CellCube system offers linear scalability by allowing multiple modules to be connected in parallel or in series. This enables you to realize greater surface area as you transition from research through process development to manufacturing.

The basic CellCube system incorporates a peristaltic pump\* and bioreactor\* to drive continuous recirculation of conditioned media through the CellCube module for efficient gas exchange and nutrient delivery. \*Non-Corning products sold separately.

- ▶ Surface treatment on both sides of the plates doubles the available surface area within the same footprint
- ▶ Encapsulation and endplates made from polycarbonate for strength and long-term reliability
- ▶ Flow control orifice and directors promote even distribution of media
- ▶ Scale-up from 8,500 cm<sup>2</sup> to 85,000 cm<sup>2</sup> is linear and uses the same pumps and controller for greater efficiency

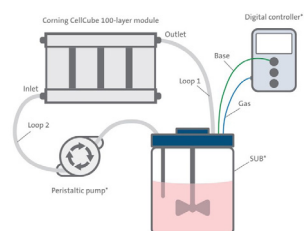

## Corning CellCube Systems Modules

Cat. No.	Description	Number of Layers	Growth Surface Area (cm <sup>2</sup> )	Surface Treatment	Qty/ Pk	Qty/ Cs
3200	CellCube 10-layer module	10	8,500	TC-treated	1	2
3231	CellCube 10-layer module with AseptiQuik® G connectors	10	8,500	TC-treated	1	2
3241	CellCube 25-layer module with AseptiQuik® G connectors	25	21,250	Corning CellBIND®	1	1
3304	CellCube 25-layer module	25	21,250	Corning CellBIND	1	1
3201	CellCube 25-layer module	25	21,250	TC-treated	1	1
3232	CellCube 25-layer module with AseptiQuik® G connectors	25	21,250	TC-treated	1	1
3264	CellCube 100-layer module	100	85,000	TC-treated	1	1
3032	CellCube 100-layer module	100	85,000	Corning CellBIND	1	1
3233	CellCube 100-layer module with AseptiQuik® G connectors	100	85,000	TC-treated	1	1
3244	CellCube 100-layer module with AseptiQuik® G connectors	100	85,000	Corning CellBIND	1	1

## Corning CellCube Accessories

Cat. No.	Description	Qty/ Pk	Qty/ Cs
3136	CellCube stainless steel stand for 25-layer module	1	1
3234	CellCube T-tubing, medium filter, 2 aseptic connectors	1	4
3235	CellCube Double-T manifold, 4 aseptic connectors	1	2
3236	CellCube Cross manifold, 4 aseptic connectors	1	4
3237	CellCube adaptor, aseptic connector to Female MPC	1	4
3238	CellCube adaptor, aseptic connector to Male MPC	1	4
92341	CellCube production cart	1	1
3158	Female MPC to Female MPC Adapter, sterile	1	5
3159	Male MPC to Male MPC Adapter, sterile	1	5
3160	Male MPC to AseptiQuik® G Adapter, sterile	1	5
3204	T Tubing Manifold, Medium Filter, 3/8" ID tubing, 2 AseptiQuik® G connectors, sterile	1	4
3214	Cross Connector, 3/8" ID Tubing, Female MPC to 3 AseptiQuik® G connectors, sterile	1	4
3278	36" Pump Tubing, 3/8" ID Tubing, 2 Male MPC connectors, sterile	1	4



Corning CellCube production cart (Cat. No. 92341)



# Closed System Solutions

Closed processing mitigates contamination and safety risks and can help reduce costs of cleanroom measures. Corning gives you the flexibility to close your processes your way.

Claims may vary by product. Product-specific claims are found on the Certificate of Compliance (CoC) for each lot of shipped product.

## Choose from Two Types of Closed System Solutions

### Catalog Product

Standard offerings are available in our catalog including aseptic transfer cap accessories or vessels with pre-attached aseptic accessories.

### Corning Configurable Assemblies

Corning configurable assemblies balance off-the-shelf speed and custom flexibility using an array of proven Corning vessels and pre-qualified components to create a finished product— a unique design—that precisely aligns with your requirements. Our streamlined implementation process ensures short lead times.

## An efficient, streamlined process for designing, testing, and ordering your finished closed assembly



### Custom Closed System Configurations

If you require more hands-on technical assistance designing a custom closed system solution, contact your Corning account representative.

# Corning® Ascent® Fixed Bed Reactor System 5

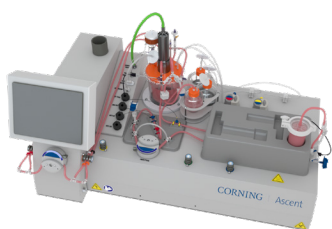

The Corning Ascent FBR System 5 is designed to enable process development and production scale cell culture capacities for cell and gene therapy workflows. The system is designed to provide viable cell harvest capability that can enable it to be used as seed train and potentially for other applications that require the ability to harvest large quantities of cells, such as regenerative medicine. Three single-use Ascent FBR bioreactor sizes: 1 m<sup>2</sup>, 2.5 m<sup>2</sup> and 5 m<sup>2</sup>, help in the development of a stable and well-defined manufacturing process.

The Corning Ascent FBR System 5 is an automated, perfusion bioproduction platform for attachment-dependent cell-based processes. The platform is designed to provide flexibility in protocol development and hands-off operation during use.

The system's consumable set is equipped with disposable sensors for key process parameters (pH, dissolved oxygen, temperature). All fluid-contacting components are pre-assembled, single-use, and irradiated, requiring no autoclaving. The system is designed to be set up and operational in as little as 20 minutes.

Specially treated woven mesh polymer substrate	<ul style="list-style-type: none"> <li>• Uniform fluid flow – efficient nutrient delivery and waste removal</li> <li>• Uniform cell growth – beneficial cell distribution and confluence at transfection</li> <li>• Improves cell health and product yield</li> </ul>
FBR designed to harvest viable cells with >90% recovery	<ul style="list-style-type: none"> <li>• Enables its use in other application workflows that require cell recovery for downstream use</li> <li>• Enables the bioreactor to be used for seed train, streamlining vessel-to-vessel cell transfer</li> </ul>
Bioreactor scalability	<ul style="list-style-type: none"> <li>• Ascent FBR System 5 bioreactors scale from 1 m<sup>2</sup> to 5 m<sup>2</sup>, helping the development of a stable and well-defined manufacturing process</li> </ul>
Separate media condition vessel (MCV)	<ul style="list-style-type: none"> <li>• Provides flexibility in media volume and dilution strategy for transfection reagents prior to addition</li> </ul>
Automated control, including disposable sensors that monitor DO, pH, temperature	<ul style="list-style-type: none"> <li>• Reduced labor costs, hands-off operation, reduced risk of human error</li> </ul>
Ready to use, irradiated consumables	<ul style="list-style-type: none"> <li>• Minimal set-up required, no autoclaving necessary, no probe calibration required. The minimal setup required can save many hours of valuable time.</li> </ul>
Closed system	<ul style="list-style-type: none"> <li>• Can be run outside a laminar flow hood. Aseptic connectors or tube welding allow for easy benchtop aseptic cell sampling of the bioreactor.</li> </ul>

The Corning Ascent FBR System 5 consists of a system controller with Human-Machine Interface (HMI) touchscreen control display and single-use, irradiated components including a bioreactor, a media conditioning vessel (MCV), and other consumables, such as tubing, connectors, probes, in-line sensors, and bottles.

During cell culture, a recirculation pump circulates media from the MCV through the fixed bed bioreactor. A separate pump aids in removing depleted media from the MCV and replacing it with fresh media during media maintenance. Cell culture pH and nutrient levels are monitored and maintained via feed and base pumps while temperature-controlled heated nests keep the MCV and bioreactor at a constant temperature. At harvest, cells are released or lysed in situ from the bioreactor at the user's discretion. The HMI allows the user flexibility to operate the system in manual or automated modes.

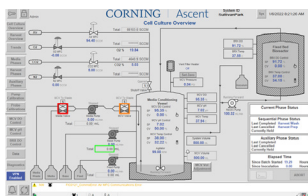

The controller is operated using a touchscreen graphic user interface.



Corning Ascent FBR System 5

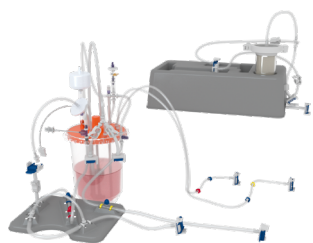

Main Consumables (MCV and BRV) with AseptiQuik® Connectors



Harvest Consumables



Accessory Consumables

## The Bioreactor Design

The Corning® Ascent® FBR system's bioreactor features a specially treated and packed polymer mesh that enables uniform, low-shear fluid flow through the bioreactor bed, which promotes evenly distributed cell growth and enhances exposure of cells to nutrients and reagents. This has demonstrated high yields that could result in fewer required runs and significant cost reduction in manufacturing.

The system allows for the removal of the FBR from the controller so it can be moved into a laminar flow hood for sampling. A sanitary twist clamp allows easy access to the segmented sampling mesh located inside the FBR. The 3 sampling mesh disks are divided into 6 segments, each designed for easy removal. Segments may be removed to monitor cell growth within the FBR at various times.

Corning Ascent FBR System 100 and System 1000 will be available in multiple surface area sizes, utilizing the same bioreactor technology as the System 5 to provide scalability from 1 m<sup>2</sup> to 1,000 m<sup>2</sup>.

### Corning Ascent FBR System 5

Cat. No.	Description	Qty/Cs
6970	Ascent FBR System 5, 120V	1
6991	Ascent FBR System 5, 230V	1

### Corning Ascent Bioreactor Consumables

Cat. No.	Description	Qty/Cs
6971	Ascent FBR 1 m <sup>2</sup> bioreactor consumable	1
6972	Ascent FBR 2.5 m <sup>2</sup> bioreactor consumable	1
6973	Ascent FBR 5 m <sup>2</sup> bioreactor consumable	1
6974	Ascent FBR 1 m <sup>2</sup> bioreactor consumable with Lynx® connectors	1
6975	Ascent FBR 2.5 m <sup>2</sup> bioreactor consumable with Lynx® connectors	1
6976	Ascent FBR 5 m <sup>2</sup> bioreactor consumable with Lynx® connectors	1

### Corning Ascent Consumables and Accessories

Cat. No.	Description	Qty/Cs
6984	Ascent 2L roller bottle with ¼" tubing and AseptiQuik® DC	2
6985	Ascent 3L Erlenmeyer flask with ¼" tubing and AseptiQuik® DC	2
6966	Ascent 5L Erlenmeyer flask with ¼" tubing and AseptiQuik® DC	2
6986	Ascent harvest consumable with 1L wash bottle	1
6987	Ascent harvest consumable with 2L wash bottle	1
6960	Ascent In Situ Lysis consumable	1
6957	Ascent FBR coating consumable with 1L storage bottle and AseptiQuik® G-DC	1
6979	Ascent 500 mL centrifuge tube with ¼" tubing and AseptiQuik® G	2
6980	Ascent 500 mL bottle with ¼" tubing and AseptiQuik® G	2
6981	Ascent 500 mL bottle with ⅜" tubing and AseptiQuik® S	4
6982	Ascent 3L Erlenmeyer flask with ¼" tubing and AseptiQuik® G	2
6983	Ascent 5L Erlenmeyer flask with ¼" tubing and AseptiQuik® G	2
6967	Ascent T-adaptor with ¼" tubing and AseptiQuik® S to G	4
6968	Ascent T-adaptor with ¼" tubing and AseptiQuik® G	4
6969	Ascent T-adaptor with ¼" tubing and AseptiQuik® S	4
6993	Ascent Accessory tubing ¼" with AseptiQuik® G	4
6961	Ascent Accessory Tubing ⅜" with AseptiQuik® G	4
6962	Ascent T-connector with ¼" tubing and AseptiQuik® G-DC to G	4
6963	Ascent Cross Connector with ¼" tubing and AseptiQuik® G-DC to G	4
6964	Ascent 1L Bottle with ¼" tubing and AseptiQuik® G	4
6965	Ascent 2L Bottle with ¼" tubing and AseptiQuik® G	2

# Microcarriers



## Scientific Support

Corning strives to provide the highest scientific support for all our products. Please contact your Corning Account Manager or Bioprocess Specialist for ideas on how to optimize Corning Polystyrene microcarrier culture to meet your scale-up needs.

Corning Polystyrene microcarriers are designed to simplify your scale-up processes. The microcarriers are sterile, ready-to-use, and available with closed systems packaging for aseptic transfer. Additionally, the microcarriers are available with a variety of surface treatments and coatings to enhance cell attachment, maximizing cell yield and viability.

- ▶ Consistency – USP Class VI polystyrene material provides a reliable platform
- ▶ Performance – Corning microcarriers are offered with a wide variety of surface treatment and coating options to enhance cell performance and yields:
  - Corning untreated surface is available for difficult to detach cell types or where self-coating is required.
  - Corning Synthemax® II substrate creates a synthetic surface on the microcarriers ideal for stem cell expansion.
  - Corning CellBIND® surface treatment for enhanced cell attachment
  - Collagen Type I coating provides extracellular matrix protein to promote cell attachment and growth.
- ▶ Sterility Assurance Level (SAL) of 10<sup>-6</sup>
- ▶ Nonpyrogenic
- ▶ Available as closed system solutions

## Specifications

Parameter	Size
Bead size	125 to 212 µm
Density	1.026 ± 0.004 g/cm <sup>3</sup>
cm <sup>2</sup> /gram	360

## Vials and Closed System Packaging

Corning Polystyrene microcarriers are available sterile and ready to use in various vial and bottled formats. Corning Polystyrene microcarriers are also available in off-the-shelf and custom closed systems packaging. Tubing, connectors, and materials are customizable based on individual needs through our Closed Systems Solutions process.

## Polystyrene Microcarriers

Cat. No.	Description	Size	Qty/Cs
3779	Corning CellBIND surface microcarriers, PS	10 g	1
4620	Corning CellBIND surface microcarriers, PS	100 g	1
4621	Corning CellBIND surface microcarriers, PS	500 g	1
3781	Low concentration Corning Synthemax II microcarriers, PS	10 g	1
4622	Low concentration Corning Synthemax II microcarriers, PS	100 g	1
4623	Low concentration Corning Synthemax II microcarriers, PS	500 g	1
3786	Collagen-coated microcarriers, PS	10 g	1
3772	Untreated microcarriers, PS	10 g	1
4624	Untreated microcarriers, PS	100 g	1
4625	Untreated microcarriers, PS	500 g	1

## Aseptic Transfer Caps for Polystyrene Microcarriers

Cat. No.	Description	Tubing	Tubing Length with Connector	Tubing Connection	Qty/Cs
4626	Aseptic transfer cap for 100g bottles – Male Luer lock	Chemically resistant, heat sealable flexible tubing, 1/8" ID, 1/4" OD	30"	Male Luer lock	1
4627	Aseptic transfer cap for 100g bottles – Male MPC	Chemically resistant, heat sealable flexible tubing, 1/4" ID, 3/8" OD	30"	Male MPC	1
4628	Aseptic transfer cap for 500g bottles – Male Luer lock	Chemically resistant, heat sealable flexible tubing, 1/8" ID, 1/4" OD	30"	Male Luer lock	1
4629	Aseptic transfer cap for 500g bottles – Male MPC	Chemically resistant, heat sealable flexible tubing, 1/4" ID, 3/8" OD	30"	Male MPC	1

MPC = medical plastic coupler.



### **Dissolvable Microcarriers**

The research use only Corning Dissolvable Microcarriers are designed to simplify the cell harvest, separation, and concentration processes. All microcarriers arrive pre-coated with either denatured Collagen or Corning Synthemax® II to enhance cell attachment for optimal yield and viability. They are dissolved within 10 to 20 minutes, allowing for the easy collection of cells without the need for microcarrier separation. Corning Dissolvable Microcarriers offer a cell separation that is faster, gentler, and more convenient than that of standard commercially available microcarriers.

- ▶ Dissolvable for easy separation of cells from microcarriers
- ▶ Optical clarity for visualizing cell morphology
- ▶ Irradiated at a minimum of 15.3 kGy
- ▶ Pre-coated for enhanced cell attachment

Dissolvable microcarriers are available in 1g, 5g, and 10g vials and 100g bottles; and with two coating options—denatured Collagen or Corning Synthemax II.

Contact a Corning Specialist for more information.

# Erlenmeyer Shaker Flasks



Corning Polycarbonate (PC) and Polyethylene terephthalate glycol-modified (PETG) Erlenmeyer flasks are ideal for all shaker culture applications. These flasks are single-use, sterile, individually packaged, and constructed of USP Class VI PC or PETG. Molded graduations are standard, and the vented threaded caps feature a 0.2  $\mu\text{m}$  hydrophobic membrane to provide continuous gas exchange while ensuring sterility with a liquid-tight seal. Choose the flask that best suits your application and cell line.

- ▶ Sterility Assurance Level (SAL) of  $10^{-6}$
- ▶ RNase-/DNase-free
- ▶ Nonpyrogenic
- ▶ BSE/TSE: Animal-free or complies with EMA/410/01 section 6.4

## Erlenmeyer Flasks

Cat. No.	Description	Material	Qty/Cs
431405	125 mL Erlenmeyer flask, vent cap, baffled bottom	PC	50
431404	125 mL Erlenmeyer flask, flat cap, baffled bottom	PC	50
431143	125 mL Erlenmeyer flask, vent cap, plain bottom	PC	50
430421	125 mL Erlenmeyer flask, flat cap, plain bottom	PC	50
431407	250 mL Erlenmeyer flask, vent cap, baffled bottom	PC	50
431406	250 mL Erlenmeyer flask, flat cap, baffled bottom	PC	50
431144	250 mL Erlenmeyer flask, vent cap, plain bottom	PC	50
430183	250 mL Erlenmeyer flask, flat cap, plain bottom	PC	50
431401	500 mL Erlenmeyer flask, vent cap, baffled bottom	PC	25
431408	500 mL Erlenmeyer flask, flat cap, baffled bottom	PC	25
431145	500 mL Erlenmeyer flask, vent cap, plain bottom	PC	25
430422	500 mL Erlenmeyer flask, flat cap, plain bottom	PC	25
431403	1L Erlenmeyer flask, vent cap, baffled bottom	PC	25
431402	1L Erlenmeyer flask, flat cap, baffled bottom	PC	25
431147	1L Erlenmeyer flask, vent cap, plain bottom	PC	25
431146	1L Erlenmeyer flask, flat cap, plain bottom	PC	25
431256	2L Erlenmeyer flask, vent cap, baffled bottom	PC	6
431255	2L Erlenmeyer flask, vent cap, plain bottom	PC	6
431280	2L Erlenmeyer flask, vent cap, plain bottom	PETG	6
431281	2L Erlenmeyer flask, vent cap, baffled bottom	PETG	6
431253	3L Erlenmeyer flask (Fernbach design), vent cap, baffled bottom	PC	4
431252	3L Erlenmeyer flask (Fernbach design), vent cap, plain bottom	PC	4
431282	3L Erlenmeyer flask, vent cap, plain bottom	PETG	4
431283	3L Erlenmeyer flask, vent cap, baffled bottom	PETG	4
431684	5L Erlenmeyer flask (Fernbach design), vent cap, baffled bottom	PC	4
431685	5L Erlenmeyer flask (Fernbach design), vent cap, plain bottom	PC	4
431284	5L Erlenmeyer flask, vent cap, plain bottom	PETG	4
431285	5L Erlenmeyer flask, vent cap, baffled bottom	PETG	4
431686*	5L Erlenmeyer flask (Fernbach design), flat cap, plain bottom	PC	4

\*Made to order. Contact a Corning representative for details.

## Replacement Erlenmeyer Flask Caps

Corning polypropylene Erlenmeyer flask caps are also available separately. They are sterile, individually packaged, and available for the 500 mL, 1L, 2L, 3L, and 5L flask sizes, and fit both PC and PETG flasks.

Cat. No.	Compatible with Flask Size	Compatible with Products	Cap Style	Qty/Cs
431372†	500 mL or 1L	430422, 431145, 431146, 431147, 431401, 431402, 431403, 431408	Vented	50
431339	2L	431255, 431256, 431280, 431281	Vented	24
431364	2L	431255, 431256, 431280, 431281	Flat	24
431340	3L	431252, 431253, 431282, 431283	Vented	24
431363	3L	431252, 431253, 431282, 431283	Flat	24
431682	5L	431284, 431285, 431684, 431685	Vented	24

†Made to order. Contact a Corning representative for details.



Vent cap for 3L flask  
(Cat. No. 431340)



Flat cap for 3L flask  
(Cat. No. 431363)



Aseptic transfer caps with terminal male Luer lock connectors for 1, 2 or 3L Erlenmeyer flasks (Cat. Nos. 431444, 431446, 431448)

### Aseptic Transfer Caps for Corning Erlenmeyer Flasks

Cat. No.	Compatible with Flask Size	Compatible with Products	Terminal Connector	Tube Size	Tube Length	Qty/Cs
431444	1L	431146, 431147, 431402, 431403	MLL	1/8" ID, 1/4" OD	36"	5
431445	1L	431146, 431147, 431402, 431403	Male MPC	1/4" ID, 3/8" OD	36"	5
431446	2L	431255, 431256, 431280, 431281	MLL	1/8" ID, 1/4" OD	36"	6
431447	2L	431255, 431256, 431280, 431281	Male MPC	1/4" ID, 3/8" OD	36"	6
431448	3L	431252, 431253, 431282, 431283	MLL	1/8" ID, 1/4" OD	36"	4
431449	3L	431252, 431253, 431282, 431283	Male MPC	1/4" ID, 3/8" OD	36"	4
11500	5L	431284, 431285, 431684, 431685	Male MPC	1/4" ID, 3/8" OD	36"	4

FLL = female Luer lock, MPC = medical plastic coupler, MLL = male Luer lock.



Aseptic transfer cap with needleless sample port and terminal male MPC connector for 5L Erlenmeyer flask (Cat. No. 11500)

### Preassembled Closed System Solutions for Corning® Erlenmeyer Flasks Polycarbonate and plain-bottom

Cat. No.	Flask Size	Bottom Type	Terminal Connector	Tube Size	Tube Length	Qty/Cs
11405	125 mL	Plain	MLL	1/8" ID, 1/4" OD	36"	6
11415	250 mL	Plain	MLL	1/8" ID, 1/4" OD	36"	4
11425	500 mL	Plain	MLL	1/8" ID, 1/4" OD	36"	2
431510	1L	Plain	MLL	1/8" ID, 1/4" OD	36"	4
431516	1L	Plain	Male MPC	1/4" ID, 3/8" OD	36"	4
431512	2L	Plain	MLL	1/8" ID, 1/4" OD	36"	3
431518	2L	Plain	Male MPC	1/4" ID, 3/8" OD	36"	3
431514	3L	Plain	MLL	1/8" ID, 1/4" OD	36"	2
431520	3L	Plain	Male MPC	1/4" ID, 3/8" OD	36"	2
11501	5L	Plain	Male MPC	1/4" ID, 3/8" OD	36"	2
11502	5L	Baffled	Male MPC	1/4" ID, 3/8" OD	36"	2

MLL = male Luer lock, MPC = medical plastic coupler, FLL = female Luer lock.



Corning Erlenmeyer flasks for closed systems solutions, MPC (Cat. Nos. 431518 and 431520)



125 mL Corning Erlenmeyer flask with dip tube and 0.2 µm filter, MLL/FLL (Cat. No. 11405)



500 mL Erlenmeyer flask with aseptic transfer cap with terminal male Luer lock connector (Cat. No. 11425)



5L Corning Erlenmeyer flask with dip tube and 0.2 µm filter, MPC (Cat. No. 11501)

## Mini Bioreactor



The Corning Mini Bioreactor is ideal for high throughput process optimization for suspension cell culture. The product consists of the Corning 50 mL centrifuge tube with a vented cap and meets USP Class VI requirements. This product is used in cell line development, clone selection, media optimization, and recombinant protein development.

The tube has a large marking spot to clearly identify tube contents and experimental parameters. Polyethylene cap has 4 vents, and the hydrophobic membrane provides gas exchange.

- ▶ Sterility Assurance Level (SAL) of  $10^{-6}$
- ▶ RNase-/DNase-free
- ▶ Nonpyrogenic
- ▶ BSE/TSE: Animal-free or complies with EMA/410/01 section 6.4

Cat. No.	Description	Qty/Pk	Qty/Cs
431720	Mini bioreactor, 50 mL with polypropylene vented cap, hydrophobic membrane	25	300

## Disposable Spinner Flasks



Disposable spinner flasks  
(Cat. Nos. 3152 and 3153)

- ▶ The Corning disposable spinner flask system comes ready-to-use with a paddle and integrated magnet, reducing the need for time-consuming assembly, cleaning, or reassembly.
- ▶ Molded from virgin polystyrene and sterilized, each spinner flask system assures a clean unit, free of detergent residues and contamination.
- ▶ The Corning disposable spinner flask system is ideal for both suspension and microcarrier cell culture applications. Vessels are designed for optimal mixing across the range of vessel sizes. A unique integrated magnet provides smooth, even paddle rotation at required speeds.
- ▶ The paddle size and height are optimized for each vessel size. A unique integrated magnet provides smooth, even rotation at required speeds on slow-speed stirrers.
- ▶ BSE/TSE: Animal-free or complies with EMA/410/01 section 6.4.

### Specifications

Parameter	125 mL (Cat. No. 3152)	500 mL (Cat. No. 3153)	1L (Cat. No. 3561)	3L (Cat. No. 3563)
Vessel height	145 mm	203.2 mm	245 mm	259 mm
Vessel diameter	63.5 mm	87.3 mm	137 mm	188 mm
Vessel width	114.8 mm	139.7 mm	203 mm	256 mm
Sidearm opening (ID)	18.8 mm	38.1 mm	39 mm	39 mm
Sidearm cap diameter (OD)	25 mm (GL 25 threads)	45 mm (GL 45 threads)	54 mm (GL 45 threads)	54 mm (GL 45 threads)
Paddle size (W x H)	39.9 x 50.0 mm	50.3 x 61.0 mm	69 x 215 mm	105 x 227 mm
Maximum drive speed	—	—	150 rpm	150 rpm
Magnet	ALNICO	ALNICO	ALNICO	ALNICO

### Disposable Spinner Flasks

Cat. No.	Description	Qty/Cs
3152	125 mL disposable spinner flask	12
3153	500 mL disposable spinner flask	12
3578	500 mL disposable spinner flask, vent cap	12
3561	1L disposable spinner flask	6
3580	1L disposable spinner flask, vent cap	6
3563	3L disposable spinner flask	4
3581	3L disposable spinner flask, vent cap	4



Disposable spinner flasks  
(Cat. Nos. 3561 and 3563)





### Replacement Disposable Spinner Flask Caps

Corning® disposable spinner flask replacement caps are available separately. Each are provided sterile and individually doubled-bagged. Caps are available for 500 mL, 1L, and 3L flask sizes.

Cat. No.	Description	Compatible with Cat. No(s).	Qty/Cs
3567	Vent cap, 0.2 µm pore	3153, 3561, 3580, 3563, 3581	4

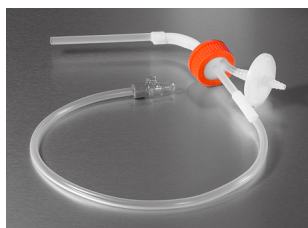

Aseptic transfer cap, MPC quick connect (Cat. Nos. 3528, 3545, and 3558)



Aseptic transfer cap, MLL quick connect (Cat. Nos. 3565, 3562, and 3564)



1L and 3L Disposable spinner flasks, MPC quick connect (Cat. Nos. 3546 and 3559)

### Aseptic Transfer Caps for Corning Disposable Spinner Flasks

Cat. No.	Description	Tubing	Tubing Length with Connector	Tubing Connection	Qty/Pk	Qty/Cs
3565	500 mL, 1/8" dip tube with 0.2 µm filter, vent	Chemically resistant, heat sealable flexible tubing, 1/8" ID, 1/4" OD	24"	MLL	1	2
3528	500 mL, 1/4" dip tube with 0.2 µm filter, vent	Chemically resistant, heat sealable flexible tubing, 1/4" ID, 3/8" OD	24"	Male MPC	1	2
3562	1L, 1/8" dip tube with 0.2 µm filter, vent	Chemically resistant, heat sealable flexible tubing, 1/8" ID, 1/4" OD	24"	MLL	1	2
3545	1L, 1/4" dip tube with 0.2 µm filter vent	Chemically resistant, heat sealable flexible tubing, 1/4" ID, 3/8" OD	24"	Male MPC	1	2
3564	3L, 1/8" dip tube with 0.2 µm filter, vent	Chemically resistant, heat sealable flexible tubing, 1/8" ID, 1/4" OD	24"	MLL	1	2
3558	3L, 1/4" dip tube with 0.2 µm filter, vent	Chemically resistant, heat sealable flexible tubing, 1/4" ID, 3/8" OD	24"	Male MPC	1	2

MPC = medical plastic coupler, MLL = male Luer lock.

### Preassembled Closed System Solutions for Corning Disposable Spinner Flasks

Cat. No.	Description	Tubing	Tubing Length with Connector	Tubing Connection	Qty/Pk	Qty/Cs
3546	1L with 3545 transfer cap	Chemically resistant, heat sealable flexible tubing, 1/4" ID, 3/8" OD	24"	Male MPC	1	6
3569	1L with 3562 transfer cap	Chemically resistant, heat sealable flexible tubing, 1/8" ID, 1/4" OD	24"	MLL	1	6
3559	3L with 3558 transfer cap	Chemically resistant, heat sealable flexible tubing, 1/4" ID, 3/8" OD	24"	Male MPC	1	4
3579	3L with 3564 transfer cap	Chemically resistant, heat sealable flexible tubing, 1/8" ID, 1/4" OD	24"	MLL	1	4

MPC = medical plastic coupler, MLL = male Luer lock.

## Preassembled Closed System Solutions for Corning Centrifuge Tubes



50 mL centrifuge tubes with MLL dip tube and 0.2  $\mu$ m filter (Cat. Nos. 11705 and 11706)



500 mL centrifuge tube with MLL dip tube and 0.2  $\mu$ m filter (Cat. No. 11750)

Cat. No.	Description	Tubing	Tubing Length with Filter	Tubing Length with Connector	Tubing Connection	Qty/ Pk	Qty/ Cs
11705	50 mL centrifuge tube with dip tube and 0.2 $\mu$ m filter with MLL/FLL end	Chemically resistant, heat sealable flexible tubing, 1/8" ID, 1/4" OD	4"	18"	MLL	1	2
11706	50 mL centrifuge tube and 0.2 $\mu$ m filter with MLL/FLL end	Chemically resistant, heat sealable flexible tubing, 1/8" ID, 1/4" OD	4"	18"	MLL	1	2
11750	500 mL centrifuge tube with dip tube and 0.2 $\mu$ m filter with MLL/FLL end	Chemically resistant, heat sealable flexible tubing, 1/8" ID, 1/4" OD and 1/4" ID, 3/8" OD	6"	20"	MLL	1	2

MLL = male Luer lock, FLL = female Luer lock.

## Preassembled Closed System Solutions for Corning® Polystyrene Storage Bottles



150 mL Easy Grip storage bottle with dip tube and filter, MLL (Cat. No. 11650)



150 mL Easy Grip storage bottle with dip tube and filter, MPC (Cat. No. 11651)



500 mL Easy Grip storage bottle with dip tube and filter, MLL (Cat. No. 11665)



500 mL Easy Grip storage bottle with dip tube and filter, MPC (Cat. No. 11666)

Cat. No.	Description	Tubing	Tubing Length with Filter	Tubing Length with Connector	Length of the Dip Tube	Tubing Connection	Qty/ Pk	Qty/ Cs
11650	150 mL Easy Grip polystyrene storage bottles with dip tube, with 0.2 µm filter, MLL/FLL	Chemically resistant, heat sealable flexible tubing, 1/8" ID, 1/4" OD and 1/4" ID, 3/8" OD	6"	24"	4.25"	MLL	1	8
11651	150 mL Easy Grip polystyrene storage bottles with dip tube, with 0.2 µm PTFE filter	Chemically resistant, heat sealable flexible tubing, 1/4" ID, 3/8" OD	4"	20"	4.25"	Male MPC	1	8
11655	250 mL Easy Grip polystyrene storage bottles with dip tube, with 0.2 µm filter, MLL/FLL	Chemically resistant, heat sealable flexible tubing, 1/8" ID, 1/4" OD and 1/4" ID, 3/8" OD	6"	24"	5"	MLL	1	6
11656	250 mL Easy Grip polystyrene storage bottles with dip tube, with 0.2 µm PTFE filter	Chemically resistant, heat sealable flexible tubing, 1/4" ID, 3/8" OD	4"	20"	5"	Male MPC	1	6
11665	500 mL Easy Grip polystyrene storage bottles with dip tube, with 0.2 µm filter, MLL/FLL	Chemically resistant, heat sealable flexible tubing, 1/8" ID, 1/4" OD and 1/4" ID, 3/8" OD	6"	24"	5.5"	MLL	1	4
11666	500 mL Easy Grip polystyrene storage bottles with dip tube, with 0.2 µm PTFE filter	Chemically resistant, heat sealable flexible tubing, 1/4" ID, 3/8" OD	4"	20"	5.5"	Male MPC	1	4
11680	1,000 mL Easy Grip polystyrene storage bottles with dip tube, with 0.2 µm filter, MLL/FLL	Chemically resistant, heat sealable flexible tubing, 1/8" ID, 1/4" OD and 1/4" ID, 3/8" OD	6"	24"	7"	MLL	1	4
11681	1,000 mL Easy Grip polystyrene storage bottles with dip tube, with 0.2 µm PTFE filter	Chemically resistant, heat sealable flexible tubing, 1/4" ID, 3/8" OD	4"	20"	7"	Male MPC	1	4

MPC = medical plastic coupler, MLL = male Luer lock, FLL = female Luer lock, PTFE = polytetrafluoroethylene.

# Single-use Bioproduction Bags

Corning single-use bioproduction bags are designed to be practical and cost-effective alternatives to rigid-walled containers. They are fabricated to match your specific application with a variety of sizes and tubing/connector configurations. These containment and delivery systems preserve the physical, chemical, and functional characteristics of sterile and process fluids. All components can be customized to match your requirements



- ▶ High quality barrier films
- ▶ Sterile
- ▶ Gas and moisture barriers to minimize transmission of oxygen, carbon dioxide, and water vapor
- ▶ Universal connection systems
- ▶ Reduces costs associated with washing, sterilization, and SIP/CIP validations
- ▶ Reduces the risks associated with cross-contamination
- ▶ Minimal setup time
- ▶ Wide variety of standard configurations
- ▶ Easily integrated in automated systems

## Industry Recognized Manufacturing Standards

- ▶ cGMP – is manufactured under a quality system that conforms to the current ISO 13485 and Quality System Regulation (21 CFR 820)
- ▶ Complete documentation and traceability
- ▶ Animal-free manufacturing process



## Custom Configuration Options

- ▶ 50 mL to 500L sizes
- ▶ 2D and 3D configurations (pillow and gusseted)
- ▶ Hanging designs
- ▶ Manifold systems
- ▶ Custom tubing and filter assemblies
- ▶ Cryopreservation bags
- ▶ Single-use bags for Corning HYPERStack® vessels

## Applications

- ▶ Bioreactor and fermentation
- ▶ Media storage and delivery
- ▶ Seed/culture/harvest/recovery
- ▶ Separation
- ▶ Downstream processing
- ▶ Filtration
- ▶ Storage of high purity water
- ▶ Waste containment



## Custom Fabrication and Assembly Services

Corning offers extensive custom design services for single-use technologies.



### Film Materials

- ▶ Ethyl vinyl acetate (EVA)
- ▶ Ultra-low density polyethylene (ULDPE)
- ▶ ULDPE/Ethylene Vinyl Alcohol (EVOH)
- ▶ Polyethylene (PE)
- ▶ Polyolefin (PO)



### Fittings

- ▶ Luer locks
- ▶ CPC connectors
- ▶ Sanitary fitting
- ▶ Hose barbs
- ▶ Spike components
- ▶ Steam-in-place (SIP) connectors

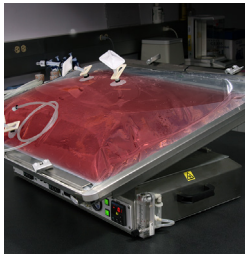

### Tubing

- ▶ Chemically resistant, heat sealable flexible tubing
- ▶ Platinum or peroxide cured silicone
- ▶ PVC

### Configuration

- ▶ Custom sizes
- ▶ Bottom ports
- ▶ 2D and 3D options
- ▶ Dip tube
- ▶ Recirculation tube



### Bag Types Available

- ▶ Multi-purpose bioproduction bags
- ▶ Cryopreservation bags
- ▶ Bags for Corning® HYPERStack® vessels

## Multi-purpose Bioproduction bags

Corning's bioproduction bags are available in 2D hanging configurations with multiple bag volumes and connector configurations.

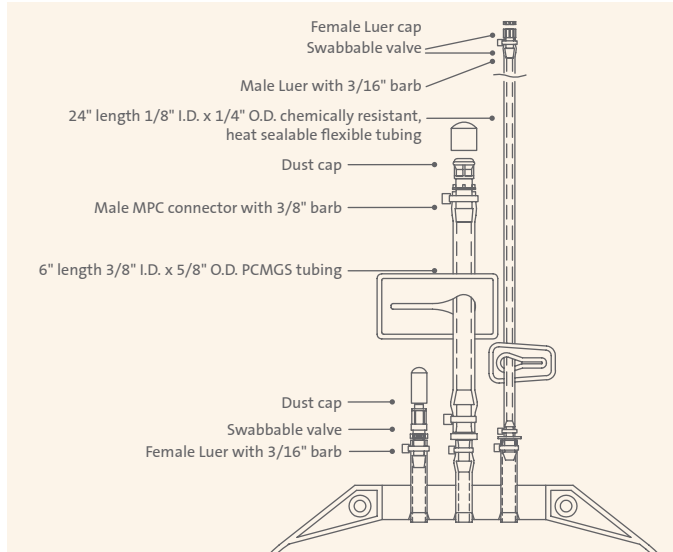

Cat. No.	Film Type	Size	Qty/Pk
91-200-01	EVA	1L	1
91-200-02	EVA	2L	1
91-200-05	EVA	5L	1
91-200-10	EVA	10L	1
91-200-20	EVA	20L	1

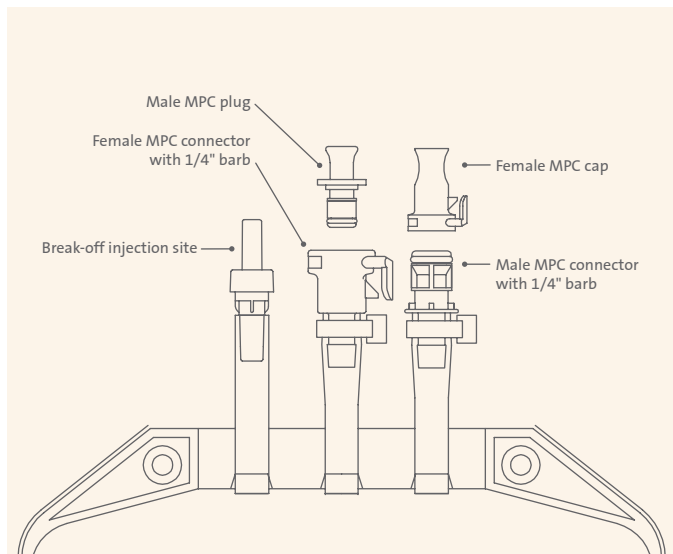

Cat. No.	Film Type	Size	Qty/Pk
91-200-41	EVA	500 mL	1
91-200-42	EVA	1L	1

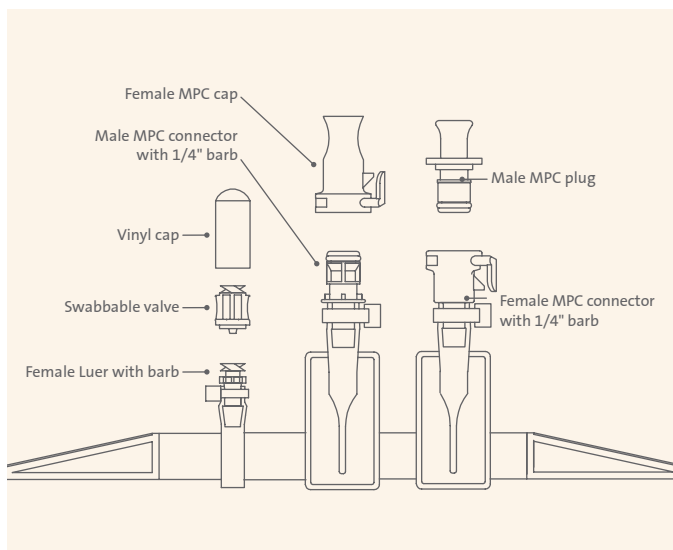

Cat. No.	Film Type	Size	Qty/Pk
91-200-36	EVA	10L	1
91-200-39	EVA	20L	1

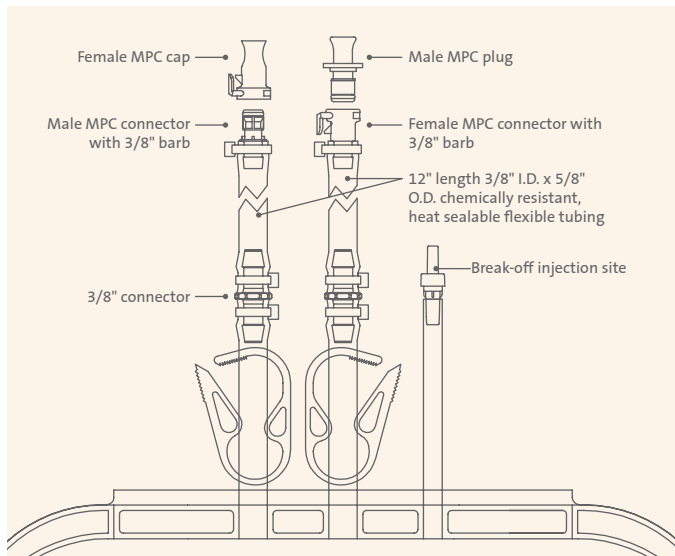

Cat. No.	Film Type	Size	Qty/Pk
91-200-43	EVA	5L	1
91-200-45	EVA	10L	1
91-200-47	EVA	20L	1
91-200-48	EVA	50L	1

### Cryopreservation Bags

Cryopreservation bags are designed for storage, preservation, and transfer of cells.

- ▶ Unique bag film material remains flexible at low temperatures (-196°C).
- ▶ Proprietary membrane port design offers thinner walls for increased flexibility and attached cap minimizes membrane exposure during freezing.
- ▶ Industry standard label pocket design offers ease-of-use and traceability in labeling.
- ▶ Polyolefin film – Proprietary EVA blend specifically selected for its low temperature properties while maintaining flexibility and clarity when filled with liquid.
- ▶ Membrane port – The attached cap snaps into place to protect the contents and minimizes membrane exposure during use.
- ▶ Label pocket – Supports use of computer-generated labels; product information can be viewed quickly by simply opening the freezing cassette
- ▶ Integral fill tube – The unique manufacturing method used to secure the fill tube to the container body eliminates the need for PVC interfaces with the liquid nitrogen storage section of the container.
- ▶ Interface/Connectors – Compatible with sterile connection technology and smart seal technology (Sebra® Model 1100 tube welder); fits in a variety of freezing cassette systems.

The physical integrity of the containers were evaluated for their ability to withstand temperature variations experienced during routine storage of hematopoietic progenitor cell products. All containers passed the physical integrity tests performed, which included initial pressure, leak, microbial challenge, and dye immersion tests.

Cell quality was assessed on our cryogenic storage containers using diluted HPC with 10% DMSO. All containers met the acceptance requirement for MNC and CD34+ cell recovery of ≥70% relative to cell counts of the sample prior to cryopreservation. The average MNC and CD34+ cell recoveries were 81% and 84%, respectively. All containers met ≥1 CFU acceptance criteria with an average of 78% recovery.

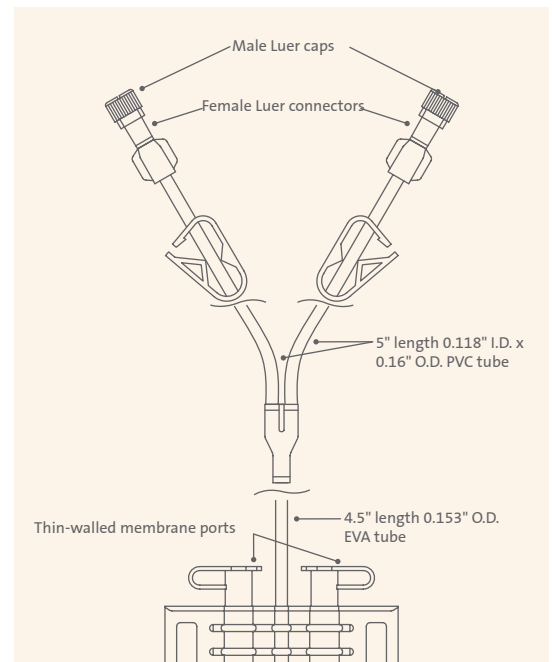

Cat. No.	Size	Fill Volume	Qty/Pk
91-200-88	50 mL	10 - 20 mL	1
91-200-89	250 mL	30 - 70 mL	1
91-200-90	500 mL	55 - 100 mL	1
91-200-91	750 mL	80 - 190 mL	1

## Tubing Sets

Optional tubing sets are available in combination with all single-use bag options.

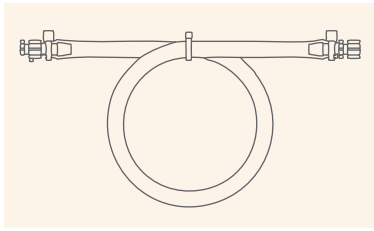

Cat. No.	Description	Qty/Pk
91-700-00	36" length 1/4" ID clear, chemically resistant, heat sealable, flexible tubing Male Luer and female Luer cap Female Luer and male Luer cap	1

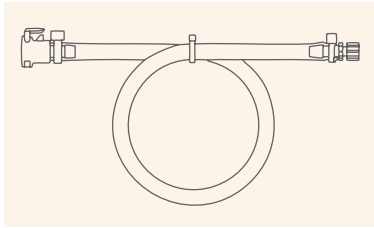

Cat. No.	Description	Qty/Pk
91-700-04	36" length 1/4" ID clear, chemically resistant, heat sealable, flexible tubing Female MPC connector Female Luer and male Luer cap	1

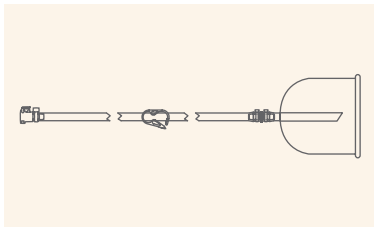

Cat. No.	Description	Qty/Pk
91-700-12	24" length 1/4" ID clear, chemically resistant, heat sealable, flexible tubing Female MPC connector with 1/4" barb Pinch clamp Filling bell	1



## Single-use Bags for Corning® HYPERStack® Vessels

These single-use bags can be connected to tubing by tube welding or by using the pre-assembled multipurpose connectors. They can be used to add media, trypsin, or quenching substrates to culture cells in an entirely closed environment.

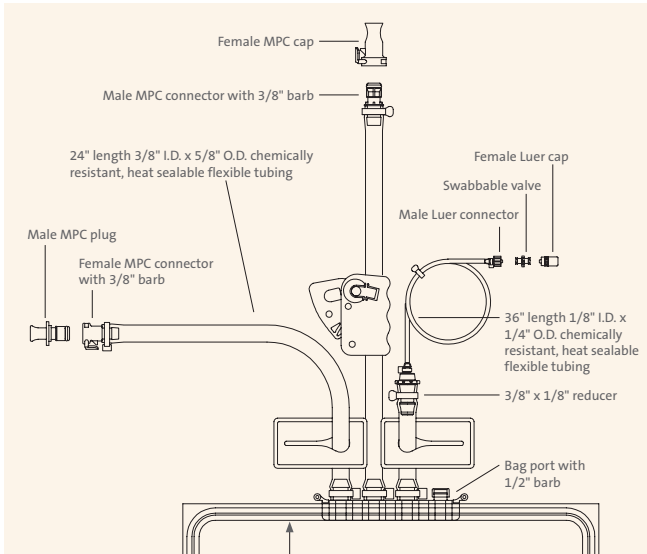

Cat. No.	Description	Film Type	Size	Qty/Pk
91-200-75	Trypsin bag	ULDPE	5L	1

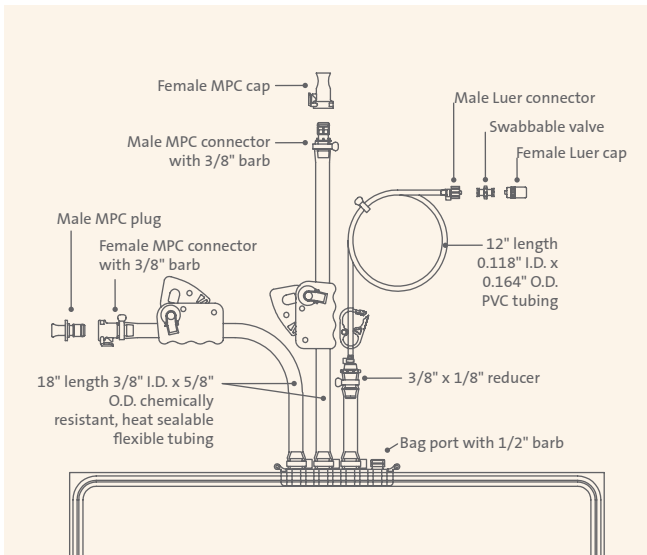

Cat. No.	Description	Film Type	Size	Qty/Pk
91-200-77	Media bag	ULDPE	20L	1

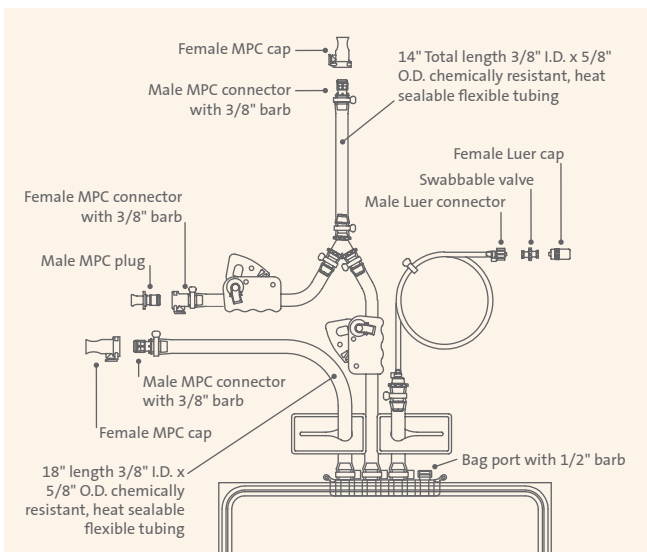

Cat. No.	Description	Film Type	Size	Qty/Pk
91-200-76	Quench bag	ULDPE	5L	1

## Ethyl Vinyl Acetate (EVA) Film

12.5 mil co-extrusion film—Collection bags.

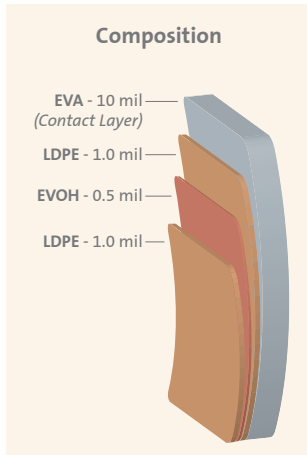

Biocompatibility Tests	Result	Test Protocol
USP intracutaneous reactivity test	Pass	USP <88>
USP acute systemic injection test	Pass	USP <88>
USP intramuscular implantation test	Pass	USP <88>
Toxicity	Nontoxic	USP <87>
Hemolysis	Non-hemolytic	ISO 10993-4
Bacterial endotoxin	<0.015 EU/mL	USP <85>

Physical Properties	Result	Test Protocol
H <sub>2</sub> O transmission (g/100 in <sup>2</sup> /24 hrs.)	0.011	ASTM F-1249
CO <sub>2</sub> transmission (cm <sup>3</sup> /100 in <sup>2</sup> /24 hrs.)	0.58	MOCN Test Method
O <sub>2</sub> transmission (cm <sup>3</sup> /100 in <sup>2</sup> /24 hrs.)	0.28	ASTM F-3985
Ultimate tensile	3,100 psi	ASTM D-638
Ultimate elongation	>650%	ASTM D-638
100% modulus	1,000 psi	ASTM D-638
Tear strength	550 lbs./in.	ASTM D-1004
Low pressure brittleness	>-75°F	ASTM D-1290
Puncture resistance	22.4 lbs.	FTMS 101 B

## Ultra-Low Density Polyethylene (ULDPE) Film

Fluid contact layer is 5.0 mil, ultra-low density polyethylene. Outer film is 5-layer, 7 mil co-extrusion film—Bags for Corning® HYPERStack® vessels, collection bags.

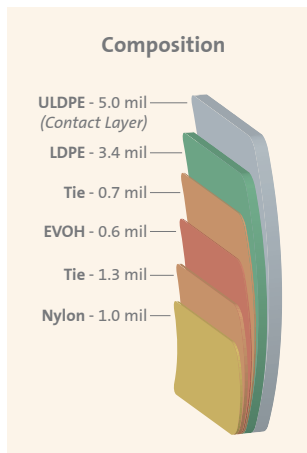

Biocompatibility Tests	Result	Test Protocol
USP intracutaneous reactivity test	Pass	USP <88>
USP acute systemic injection test	Pass	USP <88>
USP intramuscular implantation test	Pass	USP <88>
USP MEM elution method	Nontoxic	USP <87>
Physiochemical test for plastics	Pass	USP <661>

Physical Properties	Result	Test Protocol
H <sub>2</sub> O transmission (g/100 in <sup>2</sup> /24 hrs.)	0.017	ASTM F-1249
CO <sub>2</sub> transmission (cm <sup>3</sup> /100 in <sup>2</sup> /24 hrs.)	0.129	ASTM F-2476
O <sub>2</sub> transmission (cm <sup>3</sup> /100 in <sup>2</sup> /24 hrs.)	0.043	ASTM F-1927

	Average Force	Average MOE	Average Elongation	Test Protocol
Tensile strength	32.73 lbs.	25,110 psi	1,080%	ASTM D 882-02
	Min. Force	Average Force	Max. Force	Test Protocol
Tear resistance	6.77 lbs.	7.21 lbs.	7.74 lbs.	ASTM D1004-07
Puncture resistance	16.42 lbs.	18.61 lbs.	19.51 lbs.	FTMS 101C

## Polyolefin (PO) Film

Single-web, 12 mil polyolefin monolayer designed for extremely low temperatures—Cryopreservation bags.

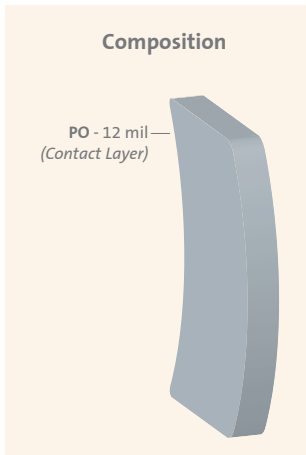

Biocompatibility Tests	Result	Test Protocol
USP Class VI	Pass	USP <88>
Toxicity	Nontoxic	USP <87>
Hemolysis	Non-hemolytic	ISO 10993-4
Heavy metals	Pass	ISO 3826-1; USP <661>
Buffering capacity	Pass	USP <661>
Non-volatile residue	Pass	USP <661>
Residue on ignition	Pass	ISO 3826-1; USP <661>
Local effects after implantation	Pass	ISO 10993-6
Irritation and delayed-type sensitivity	Pass	ISO 10993-10
Systemic toxicity	Pass	ISO 10993-11
Bacterial endotoxin	<20 EU/device	USP <85>

Physical Properties	Result	Test Protocol
H <sub>2</sub> O transmission g/100 in <sup>2</sup> /24 hrs. at 25°C	1.1	ASTM F1249
CO <sub>2</sub> transmission cm <sup>3</sup> /100 in <sup>2</sup> /24 hrs. at 25°C, 0% RH	1,477	ASTM F2476
O <sub>2</sub> transmission cm <sup>3</sup> /100 in <sup>2</sup> /24 hrs. at 25°C, 0% RH	180	ASTM D3985
Tensile strength (Mpa)	17	ASTM D882
Elongation at break, MD/TD (%)	560/700	ASTM D882
Elastic modulus (Mpa)	17	ASTM D882
Break at cold temperature (°C)	Below -80°C	ISO 8570
Glass transition temperature (Tg)	-48°C	DSC
Density (g/cm <sup>3</sup> )	0.92	ASTM D792
Low temperature, (remains flexible)	-196°C	--

# Catalog Number Index

Cat. No.	Page No.	Cat. No.	Page No.	Cat. No.	Page No.	Cat. No.	Page No.	Cat. No.	Page No.
91-200-01	20	3272	2	4620	10	11502	13	431198	1
91-200-02	20	3278	6	4621	10	11650	17	431252	12
91-200-05	20	3281	3	4622	10	11651	17	431253	12
91-200-10	20	3282	3	4623	10	11655	17	431255	12
91-200-20	20	3283	3	4624	10	11656	17	431256	12
91-200-36	20	3284	3	4625	10	11665	17	431280	12
91-200-39	20	3303	2	4626	10	11666	17	431281	12
91-200-41	20	3304	6	4627	10	11680	17	431282	12
91-200-42	20	3310	2	4628	10	11681	17	431283	12
91-200-43	21	3311	2	4629	10	11705	16	431284	12
91-200-45	21	3312	2	6957	9	11706	16	431285	12
91-200-47	21	3313	2	6960	9	11750	16	431321	1
91-200-48	21	3319	2	6961	9	11757	4	431329	1
91-200-75	23	3320	2	6962	9	11758	4	431339	12
91-200-76	23	3321	2	6963	9	11759	4	431340	12
91-200-77	23	3324	4	6964	9	11760	4	431344	1
91-200-88	21	3328	3	6965	9	11761	4	431345	1
91-200-89	21	3329	3	6966	9	11762	4	431363	12
91-200-90	21	3330	2	6967	9	11763	4	431364	12
91-200-91	21	3331	3	6968	9	11764	4	431372	12
91-700-00	22	3333	3	6969	9	11765	4	431401	12
91-700-04	22	3334	3	6970	9	11766	4	431402	12
91-700-12	22	3339	3	6971	9	11902	3	431403	12
3032	6	3528	15	6972	9	11931	4	431404	12
3136	6	3545	15	6973	9	20012	5	431405	12
3152	14	3546	15	6974	9	20013	5	431406	12
3153	14	3558	15	6975	9	20036	5	431407	12
3158	6	3559	15	6976	9	20037	5	431408	12
3159	6	3561	14	6979	9	31292	1	431444	13
3160	6	3562	15	6980	9	92341	6	431445	13
3200	6	3563	14	6981	9	430183	12	431446	13
3201	6	3564	15	6982	9	430195	1	431447	13
3204	6	3565	15	6983	9	430421	12	431448	13
3214	6	3567	15	6984	9	430422	12	431449	13
3231	6	3569	15	6985	9	430699	1	431510	13
3232	6	3578	14	6986	9	430849	1	431512	13
3233	6	3579	15	6987	9	430851	1	431514	13
3234	6	3580	14	6991	9	430852	1	431516	13
3235	6	3581	14	6993	9	430853	1	431518	5, 13
3236	6	3718	4	10042	5	431132	1	431520	13
3237	6	3719	4	10043	1, 5	431133	1	431644	1, 5
3238	6	3732	3	10047	5	431134	1	431682	12
3241	6	3772	10	11370	5	431135	1	431684	12
3244	6	3779	10	11380	5	431143	12	431685	12
3264	6	3781	10	11405	13	431144	12	431686	12
3268	2	3786	10	11415	13	431145	12	431720	14
3269	2	3907	1	11425	13	431146	12		
3270	2	3968	3	11500	13	431147	12		
3271	2	3969	3	11501	5, 13	431191	1		

**Warranty/Disclaimer:** Unless otherwise specified, all products are for research use or general laboratory use only.\* Not intended for use in diagnostic or therapeutic procedures. Not for use in humans. These products are not intended to mitigate the presence of microorganisms on surfaces or in the environment, where such organisms can be deleterious to humans or the environment. Corning Life Sciences makes no claims regarding the performance of these products for clinical or diagnostic applications. \*For a listing of US medical devices, regulatory classifications or specific information on claims, visit [www.corning.com/resources](http://www.corning.com/resources).

*Corning's products are not specifically designed and tested for diagnostic testing. Many Corning products, though not specific for diagnostic testing, can be used in the workflow and preparation of the test at the customers discretion. Customers may use these products to support their claims. We cannot make any claims or statements that our products are approved for diagnostic testing either directly or indirectly. The customer is responsible for any testing, validation, and/or regulatory submissions that may be required to support the safety and efficacy of their intended application.*

# CORNING

**Corning Incorporated**  
Life Sciences

[www.corning.com/lifesciences](http://www.corning.com/lifesciences)

## **NORTH AMERICA**

t 800.492.1110  
t 978.442.2200

## **ASIA/PACIFIC**

### **Australia/New Zealand**

t 61 427286832

### **Chinese Mainland**

t 86 21 3338 4338

## **India**

t 91 124 4604000

## **Japan**

t 81 3-3586 1996

## **Korea**

t 82 2-796-9500

## **Singapore**

t 65 6572-9740

## **Taiwan**

t 886 2-2716-0338

## **EUROPE**

[CEurope@corning.com](mailto:CEurope@corning.com)

## **France**

t 0800 916 882

## **Germany**

t 0800 101 1153

## **The Netherlands**

t 020 655 79 28

## **United Kingdom**

t 0800 376 8660

## **All Other European Countries**

t +31 (0) 206 59 60 51

## **LATIN AMERICA**

[grupoLA@corning.com](mailto:grupoLA@corning.com)

## **Brazil**

t 55 (11) 3089-7400

## **Mexico**

t (52-81) 8158-8400

AseptiQuik® is a registered trademark of Colder Products Company.

Lynx® is a registered trademark of Merck KGaA, Darmstadt, Germany or its affiliates.

For a listing of trademarks, visit [www.corning.com/clstrademarks](http://www.corning.com/clstrademarks). All other trademarks are the property of their respective owners.

© 2016-2024 Corning Incorporated. All rights reserved. 11/24 CLS-BP-028 REV8