

# EDGE® and Plug & Play™ Link Loss Budget Determination

## AEN 115, Revision: 3

### Purpose

The purpose of this document is to explain how to determine link loss budgets for EDGE® and Plug & Play™ systems comprised of modular cable assemblies (components). Loss budgets are determined for several different scenarios.

### Introduction

Optical links built from modular, factory-built cable assemblies such as Corning Optical Communications EDGE® and Plug & Play™ products offer several benefits with respect to ease of installation and network maintenance. However, those accustomed to calculating link loss budgets as a sum of the maximum allowable losses of each component may need to familiarize themselves with these modular components and how product specifications should be used to derive a link loss budget.

Each Plug & Play system component typically contains fibers in multiples of twelve. Each fiber is factory-terminated at both ends of each assembly with connectors. The five basic types of Plug & Play modular components are:

Trunks – 12- to 864-fiber cable assemblies of customer specified length terminated on one or both ends with 12-fiber MTP or single-fiber connectors.

Harnesses – break out assemblies from MTP to single fiber connectors or 12 Fiber MTPs to 8-fiber MTPs cable assemblies made from interconnect cable. Normally, one end of the harness is connected into the electronic equipment port.

Modules – Cable assemblies terminated in the same manner as harnesses, but much shorter and made from optical fiber rather than interconnect cables. The fiber portion is protected within a plastic or metal casing that mounts in housing like a patch panel. The front ports of the modules are accessed with jumpers and the rear of the module is commonly mated to a trunk.

CORNING

## Product Specifications

All EDGE® and Plug & Play™ components are manufactured and sold in accordance with an insertion loss specification that comprises the loss of all elements (fiber and connectors) of the assembly when it is mated to test jumpers. Table 1 and Table 2 depict component loss specifications.

Table 1 – Component and mated pair loss  
Specifications for multimode Low-Loss system

Component Type	Component Loss	
	Single – Mode	Multimode
Modules	1.0 dB	0.5 dB
Harness	1.0 dB + fiber loss	0.5 dB

Mated Pair Type	Mated Pair Loss	
	Single – Mode	Multimode
MTP mated pair	0.75 dB	0.25 dB
LC mated pair	0.25 dB	0.10 dB

Table 2 – Component and Mated Pair loss  
Specifications for multimode Ultra Low-Loss Systems

Component Type	Component Loss	
	Single – Mode	Multimode
EDGE8™ and EDGE Ultra Low-Loss Modules	0.60dB	0.35 dB
EDGE8 and EDGE Ultra Low-Loss Harness	0.60dB + Fiber Loss	0.35 dB + Fiber Loss

Component Type	Component Loss
EDGE AO Conversion module	0.5 dB
EDGE AO Conversion Harness	0.5 dB
EDGE AO 8 Fiber Harness	0.35 dB + Fiber Loss

Mated Pair Type	Mated Pair Loss	
	Single – Mode	Multimode
Ultra Low-Loss MTP mated pair	0.35dB	0.25 dB
Ultra Low-Loss LC mated pair	0.25dB	0.10 dB

Note: Mated pair max loss for connectors of like performance

Table 3 – Fiber attenuation specifications

Fiber Type	Maximum Attenuation (dB/km)
<b><u>Multimode</u></b>	<b><u>850/1300 nm</u></b>
OM3 (50/125 μm)	2.8/1.0
OM4 (50/125 μm)	2.8/1.0
<b><u>Single – Mode</u></b>	<b><u>1310/1550 nm</u></b>
OS2	0.4/0.3

**Note(1):** Please refer to EDGE® and Plug & Play™ Spec sheets to determine dB loss of the different products offered.

**Note(2):** Ultra Low-Loss products are only offered with EDGE® Systems. All EDGE trunks with manufacturing dates after September 2014 have an MTP specification of 0.25dB max.

### Factory Testing of Insertion Loss

It is not possible to measure the loss contribution of each individual element within a component using a power meter. However, total component insertion loss measurements are made across each terminated fiber within the component. Measurements are evaluated against factory pass/fail criteria, which are set at or below the component insertion loss specification.

### Link Loss Budgets vs. Component Specifications

A simple summation of the insertion loss specifications for all components within a link will lead to an incorrect link loss budget – that is – to a higher budget than what should actually be allowed during system design and link testing. This overestimated budget is a result of budgeting twice for the mated pairs shared between two components. To illustrate, consider the factory testing of two separate components. Each component will be tested against the component specification with a factory test jumper on each end. This means the loss of two connector pairs per component will be measured. But when two components are mated together in a link, the components share a mated pair, meaning that the number of connector pairs in the system totals only three, not four. Therefore, the link budget should be something less than the summation of all individual component loss specifications.

The following pages show the most common link configurations and their link loss budget calculation with this method for Low-Loss and Ultra Low-Loss performance multimode systems. Note that all scenarios are calculated using multimode losses. For single-mode systems, refer to the tables above for appropriate loss values.

**Refer to the table of contents below to identify the scenario pertaining to your system configuration:**

**1) *Low-Loss and Ultra Low-Loss Products:***

Equipment - Jumper - Module - Trunk - Module - Jumper - Equipment

**2) *Low-Loss and Ultra Low-Loss Products:***

Equipment - Jumper - Module - Trunk - Extender Trunk - Module - Jumper - Equipment

**3) *Low-Loss and Ultra Low-Loss Products:***

Equipment - Jumper - Module - Trunk - Harness - Equipment

**4) *Low-Loss and Ultra Low-Loss Products:***

Equipment - Jumper - Module - Hybrid Trunk or module harness - Equipment

**5) *Low-Loss and Ultra Low-Loss Products:***

Equipment - MTP Jumper - Trunk - MTP Jumper - Equipment

**6) *Low-Loss and Ultra Low-Loss Products:***

Equipment - MTP Jumper - Conversion module - Trunk - Conversion module - MTP Jumper - Equipment

**7) *Low-Loss and Ultra Low-Loss Products:***

Equipment - Conversion harness - Trunk - Conversion harness - Equipment

**8) *Low-Loss and Ultra Low-Loss Products:***

Equipment - Conversion module - Trunk - Conversion harness - Equipment

**9) *Low-Loss and Ultra Low-Loss Products:***

Equipment - MTP Jumper - Trunk - module - LC Jumper - Equipment

**10) *Low-Loss and Ultra Low-Loss Products:***

Equipment - MTP Jumper - Conversion module - Trunk - module - LC Jumper - Equipment

**Scenario 1:**

Equipment - Jumper - Module - Trunk - Module - Jumper - Equipment

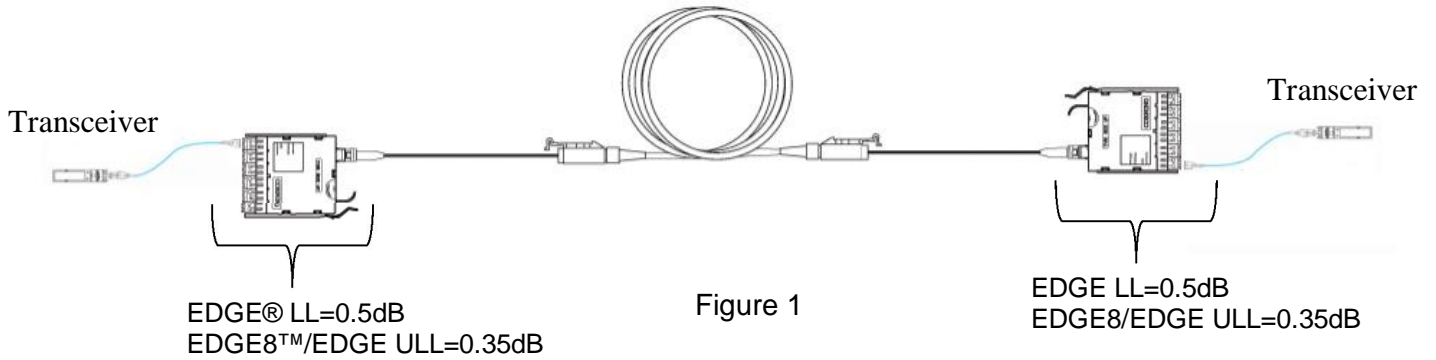

**LL Budget Loss Calculation** = 0.5dB + (System length (km) x fiber performance (dB/km)) + 0.5dB

**ULL Budget Loss Calculation** = 0.35dB + (System length (km) x fiber performance (dB/km)) + 0.35dB

**Scenario 2:**

Equipment - Jumper - Module - Trunk - Extender Trunk - Module - Jumper - Equipment

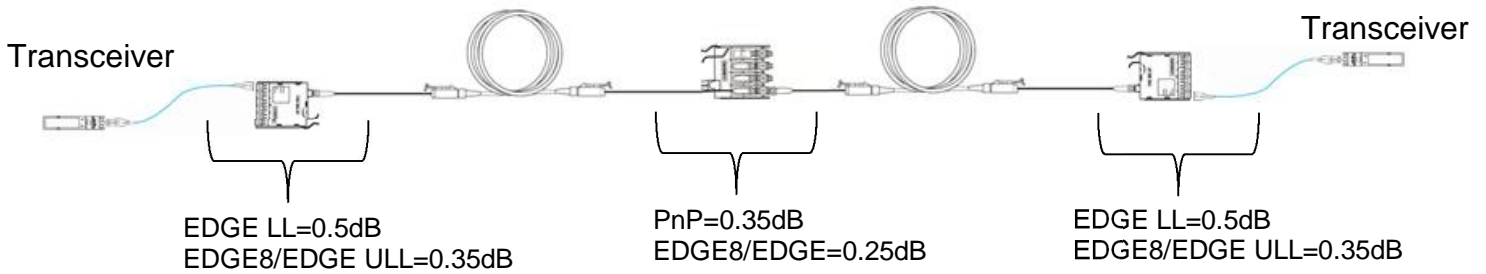

**LL Budget Loss Calculation** = 0.5dB + ((System length (km)) x fiber performance loss (dB/km)) + 0.35dB + 0.5dB

**ULL Budget Loss Calculation** = 0.35dB + ((System length (km)) x fiber performance loss (dB/km)) + 0.25dB + 0.35dB

**Scenario 3:**

Equipment - Jumper - Module - Trunk - Harness - Equipment

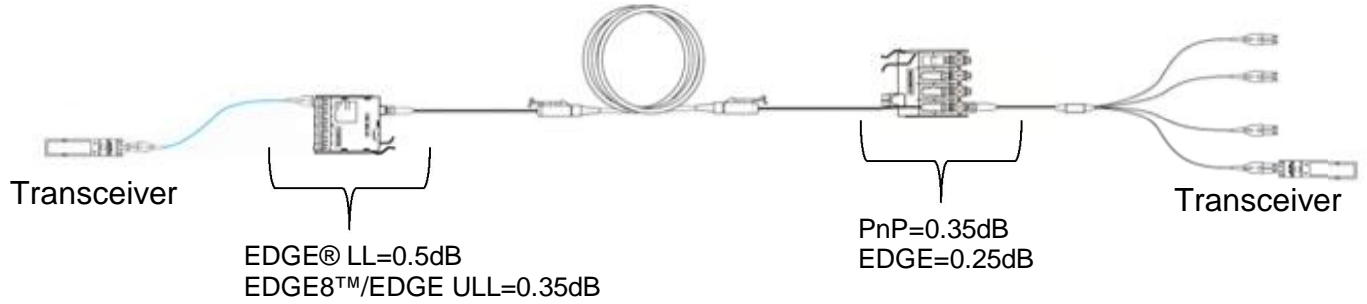

Figure 3

**LL Budget Loss Calculation** = 0.5dB + (System length (km) x fiber performance (dB/km)) + 0.35dB

**ULL Budget Loss Calculation** = 0.35dB + (System length (km) x fiber performance (dB/km)) + 0.25dB

**Scenario 4:**

Equipment - Jumper - Module - Hybrid Trunk or module harness - Equipment

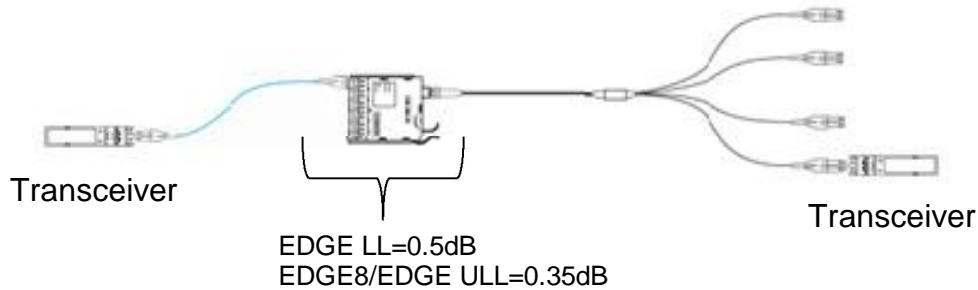

Figure 4

**LL Budget Loss Calculation** = 0.5dB + (System length (km) x fiber performance (dB/km))

**ULL Budget Loss Calculation** = 0.35dB + (System length (km) x fiber performance (dB/km))

**Scenario 5:**

Equipment - MTP Jumper - Trunk - MTP Jumper - Equipment

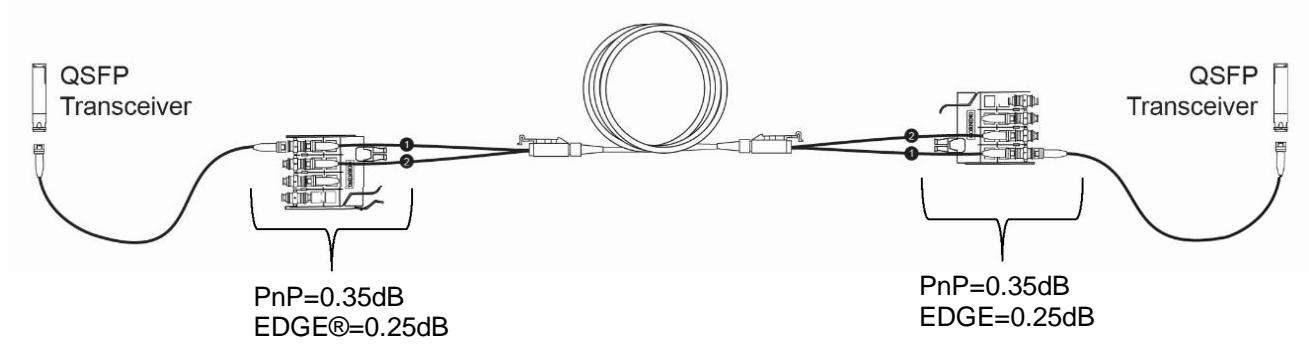
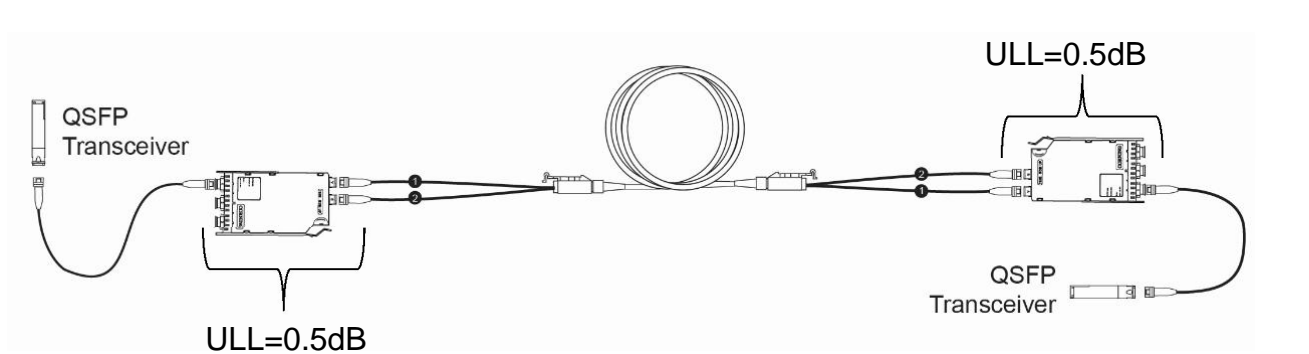

Figure 5

**PnP Budget Loss Calculation** = 0.35dB + ((System length (km) x fiber performance (dB/km)) + 0.35dB  
**EDGE Budget Loss Calculation** = 0.25dB + ((System length (km) x fiber performance (dB/km)) + 0.25dB

**Scenario 6:**

Equipment - MTP Jumper - Conversion Module- Trunk - Conversion Module -MTP Jumper - Equipment



**Budget Loss Calculation** = 0.5dB + ((System length (km) x fiber performance (dB/km)) + 0.5dB

**Scenario 7:**

Equipment - Conversion Harness- Trunk - Conversion Harness - Equipment

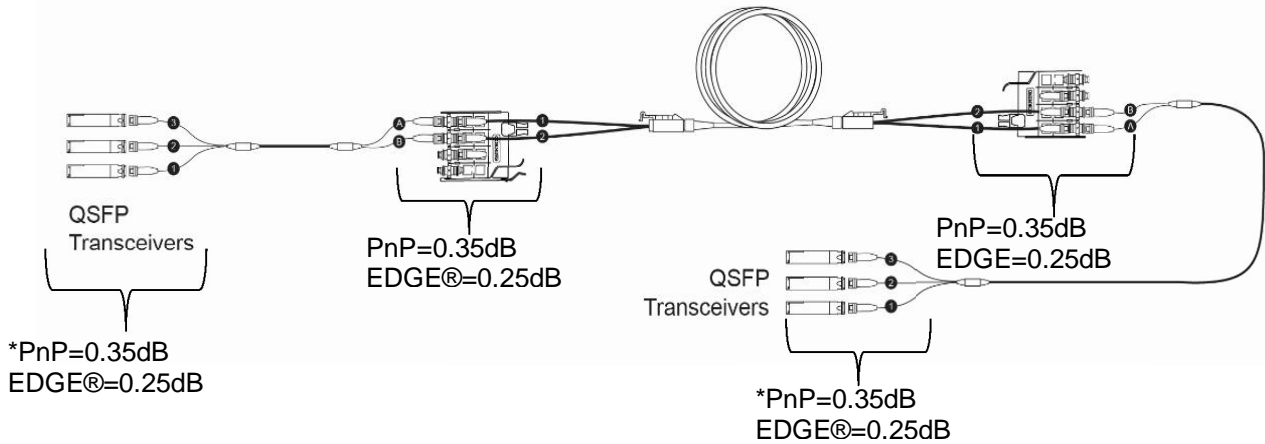

Figure 7

**Budget Loss Calculation** = 0.25dB + 0.25 + ((System length (km) x fiber performance (dB/km))+0.25dB+0.25dB

**Scenario 8:**

Equipment - MTP Jumper- Conversion Module - Trunk - Conversion Harness - Equipment

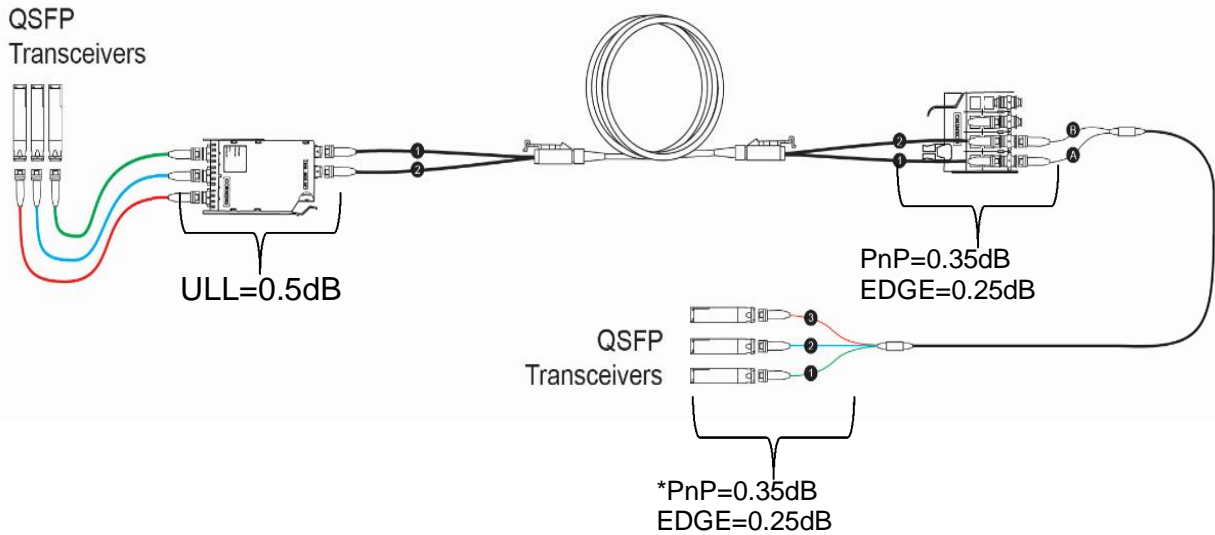

Figure 8

**Budget Loss Calculation** = 0.5dB + (System length (km) x fiber performance (dB/km))+0.25dB+0.25dB.



**\*NOTE for scenario 7 and 8:**

The eight fiber MTPs from the conversion harness that connect to the QSFP transceivers are included in the budget calculation, but does not add any loss to the system. These are included for testing purposes and help to maintain a base eight MTP to base eight MTP testing.

Equipment - MTP Jumper - Trunk - Module - LC Jumper - Equipment

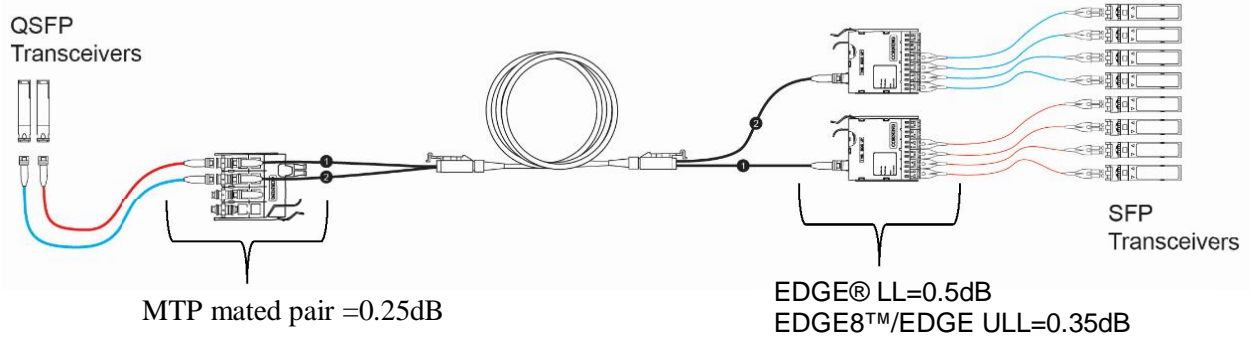
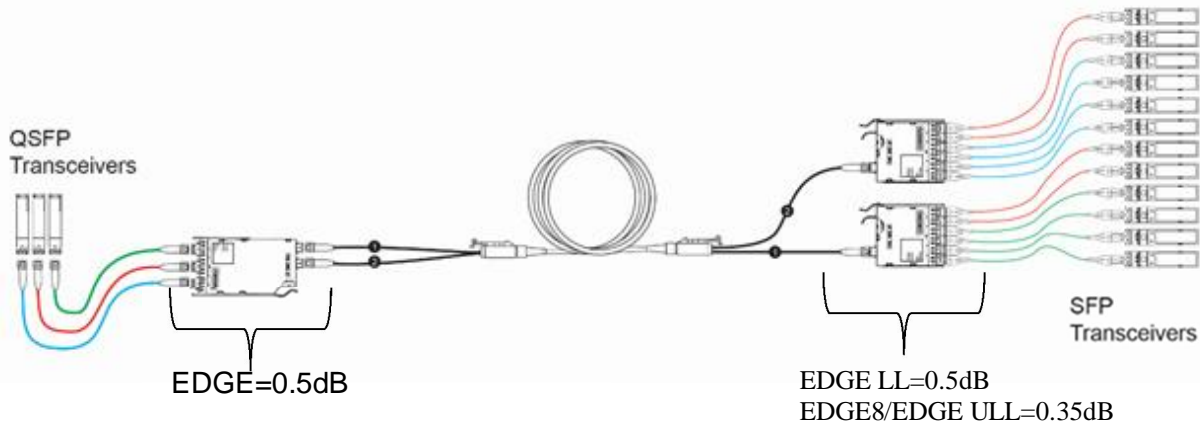

Figure 9

**LL Budget Loss Calculation** = 0.25dB + (System length (km) x fiber performance (dB/km)) + 0.5dB  
**ULL Budget Loss Calculation** = 0.25dB + (System length (km) x fiber performance (dB/km)) + 0.35dB

**Scenario 10:**

Equipment - MTP Jumper - Conversion Module - Trunk - Module - Jumper - Equipment



**LL Budget Loss Calculation** = 0.5dB + (System length (km) x fiber performance (dB/km)) + 0.5dB  
**ULL Budget Loss Calculation** = 0.5dB + (System length (km) x fiber performance (dB/km)) + 0.35dB

For additional questions with regard to product specifications and budget calculations contact Corning Optical Communications, Engineering Services' Technical Support at 1-800-743-2761.